An architectural rendering of a city street scene. In the foreground, a green and white tram is moving along a dedicated track. To its left, a multi-lane road has several cars, including a white SUV and a silver sedan. Further left, a wide sidewalk is populated with several stylized human figures walking. The background shows modern multi-story buildings and trees under a clear sky. The entire scene is overlaid with semi-transparent geometric shapes in shades of blue, green, and red.

MARCH 7 2016

DUKE Heights BIA **Public Realm Design Report**

PUBLIC STREETScape & PUBLIC REALM
MASTERPLAN DESIGN STUDY

The Planning Partnership

MARCH 7 2016

DUKE Heights Public Realm Design Report

PUBLIC STREETScape & PUBLIC REALM
MASTERPLAN DESIGN STUDY

The Planning Partnership

TOC // contents

EXEC // SUMMARY 7

ONE // INTRODUCTION 9

1.1 Context 9

1.2 Study Area 11

TWO // THE PUBLIC REALM 13

2.1 Improving the Public Realm 13

2.2 Economic Benefits of Public Realm Investment 15

THREE // VISION & PRINCIPLES 17

3.1 Vision 16

3.2 Guiding Principles 17

FOUR // DESIGN ELEMENTS 21

4.1 Balance Of Users 21

*4.2 Consolidation and Reorganization
of Streetscape Elements 22*

4.3 Establishing the Brand 27

4.4 Greening the Public Realm 28

4.5 Special Features 33

FIVE // STREETSCAPE DETAILS 35

SIX // IMPLEMENTATION 55

SEVEN // APPENDIX 61



EXEC // summary

Introduction

The DUKE Heights Business Improvement Area was formed in 2013 in response to the significant investment in public transportation infrastructure in the area, including the Toronto York Spadina Subway Extension (TYSSE) and Finch West LRT.

Given that the BIA serves over 2500 businesses, and is the 2nd largest in the City, the development of a cohesive streetscape and public realm strategy is of the utmost importance.

The intersection of Keele and Finch will now serve as a major mobility hub, increasing the already significant commuter volume. In order to set a precedent for future public realm and streetscaping investment in the area, the BIA set forth in establishing the Finch and Keele intersection, specifically the block from Keele Street eastbound to Tangiers Road, as the major gateway, business hub and heart of the BIA.

The momentum generated through the significant transit investment provides unparalleled incentive to develop a state of the art public realm that will not only inform the rest of the DUKE Heights BIA but also promote this form of streetscaping and urban design through other similar scaled and typically auto-centric neighbourhoods in the immediate vicinity and elsewhere in the city.

This Public Realm Design Report is intended to outline the intentions of the BIA with respect to public realm and streetscape improvements, and provide guidance on how to best achieve these intentions.

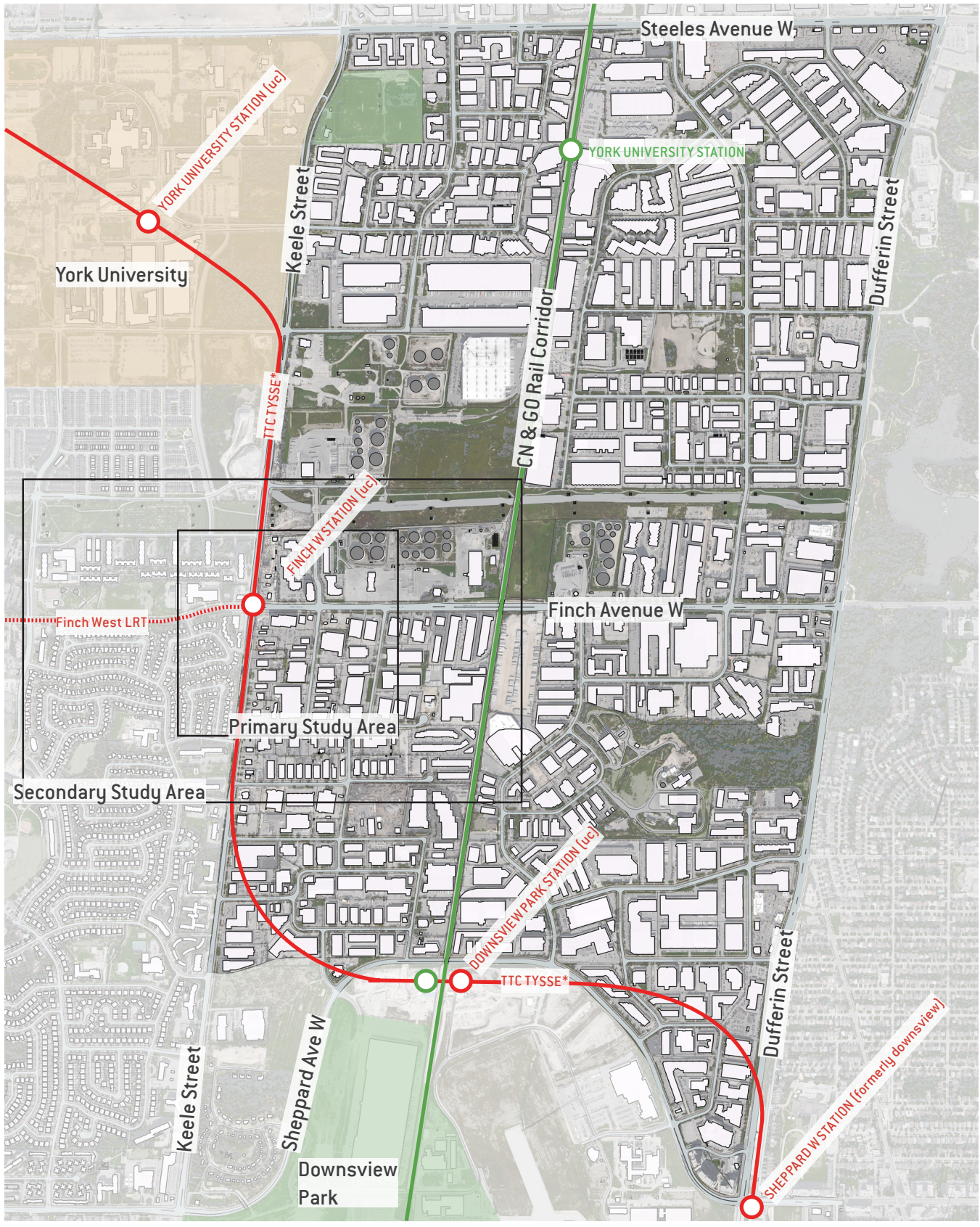

MAP OF EXISTING BIA

* TYSSE = Toronto-York Spadina Subway Extension

ONE // introduction

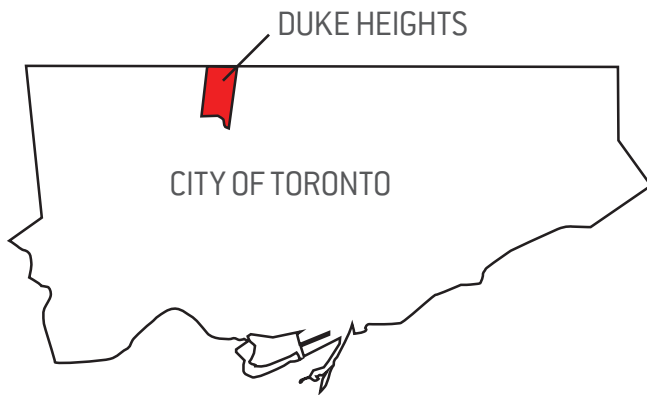

Key Characteristics

- Low rise commercial industrial mix
- Overlooked assets
- Vehicles dominate the public realm
- Poorly connected pedestrian routes
- Tremendous transit connectivity

1.1 Context

The DUKE Heights BIA is bounded by Steeles Avenue, Dufferin Street, Sheppard Avenue, and Keele Street.

DUKE Heights, which draws its name from the first two letters of Dufferin and Keele represents more than 2,500 businesses and 30,000 employees within the BIA. There are a number of large construction projects ongoing, including but not limited to the terminus stop of the westbound Finch LRT, several stops along the Toronto-York Spadina Subway Extension. The BIA is also surrounded by important amenities including York University and Downsview Park which is an ever evolving destination for recreation, education, ecology, and a unique escape within the city.

The BIA's physical characteristics can be generally described as low-rise warehouse commercial and industrial. New residential development exists at the southeastern corner where new high density residential has begun to cluster around Downsview subway station.

Although primarily low rise architecture, with wide rights-of-way, new uses have begun to spring up throughout as the neighbourhood continues to evolve.

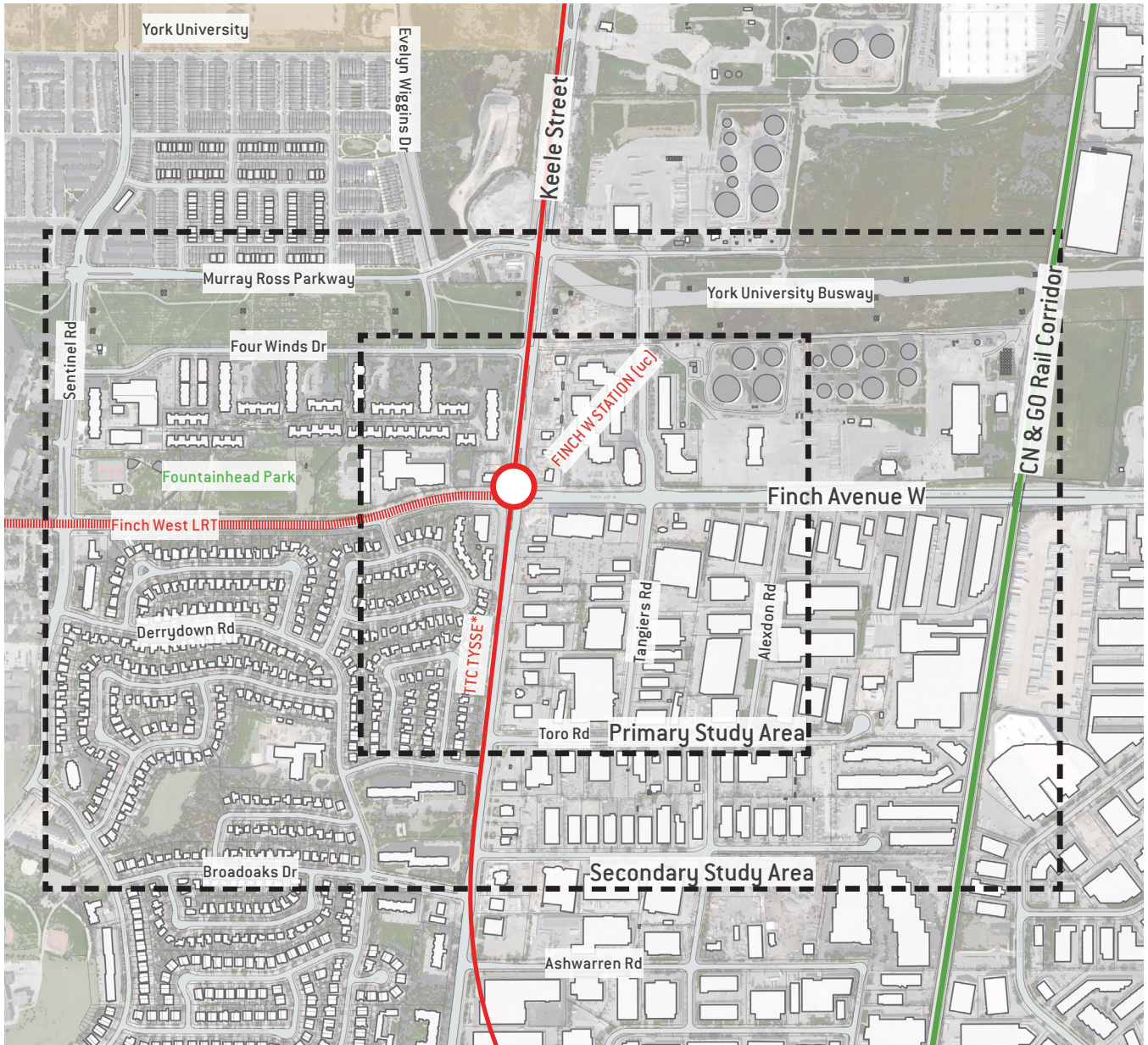

MAP OF
PRIMARY &
SECONDARY
STUDY AREAS

1.2 Study Area

As previously noted, this Report came to fruition as a response to the several public infrastructure projects occurring at the intersection of Finch Ave. W. and Keele Street. Public Realm and Streetscape design direction and details were developed to inform these respective infrastructure projects, and form the basis of this Report. This Report is intended to provide guidance for future public realm investment and to serve as a precedent for more detailed and complete urban design guidelines for the entire BIA.

For the purpose of this Report, the Study Area is focused on the Finch Ave. W. and Keele Street intersection, and is, divided into two parts: the smaller Primary Study Area and a larger Secondary Study Area. The Primary Study Area is bounded by Four Winds Drive to the north and Toro Road to the south, Romfield Lane to the west and Alexdon Road to the east. The Secondary Study Area is bounded by Murray Ross Parkway to the north, Lepage Court to the south, Sentinel Road to the west and the CP railway line to the east.

The DUKE Heights BIA is investing in public realm and streetscape improvements as a first step in establishing itself as a prominent and attractive employment district. Rationale for public realm improvements as well as the components of successful streetscapes are outlined on the following pages.

This Report has been developed through thorough review of the City of Toronto Streetscape Manual, the Metrolinx Design Excellence Manual, and the Toronto York Spadina Subway Extension design work to date. The intention is to create a seamless public realm that blends the several plans together, and to not only complement but to enhance the public realm through specific place-sensitive recommendations.



Keele and Finch Intersection



York University Busway looking southeast



Finch Avenue West looking eastbound to Keele Street

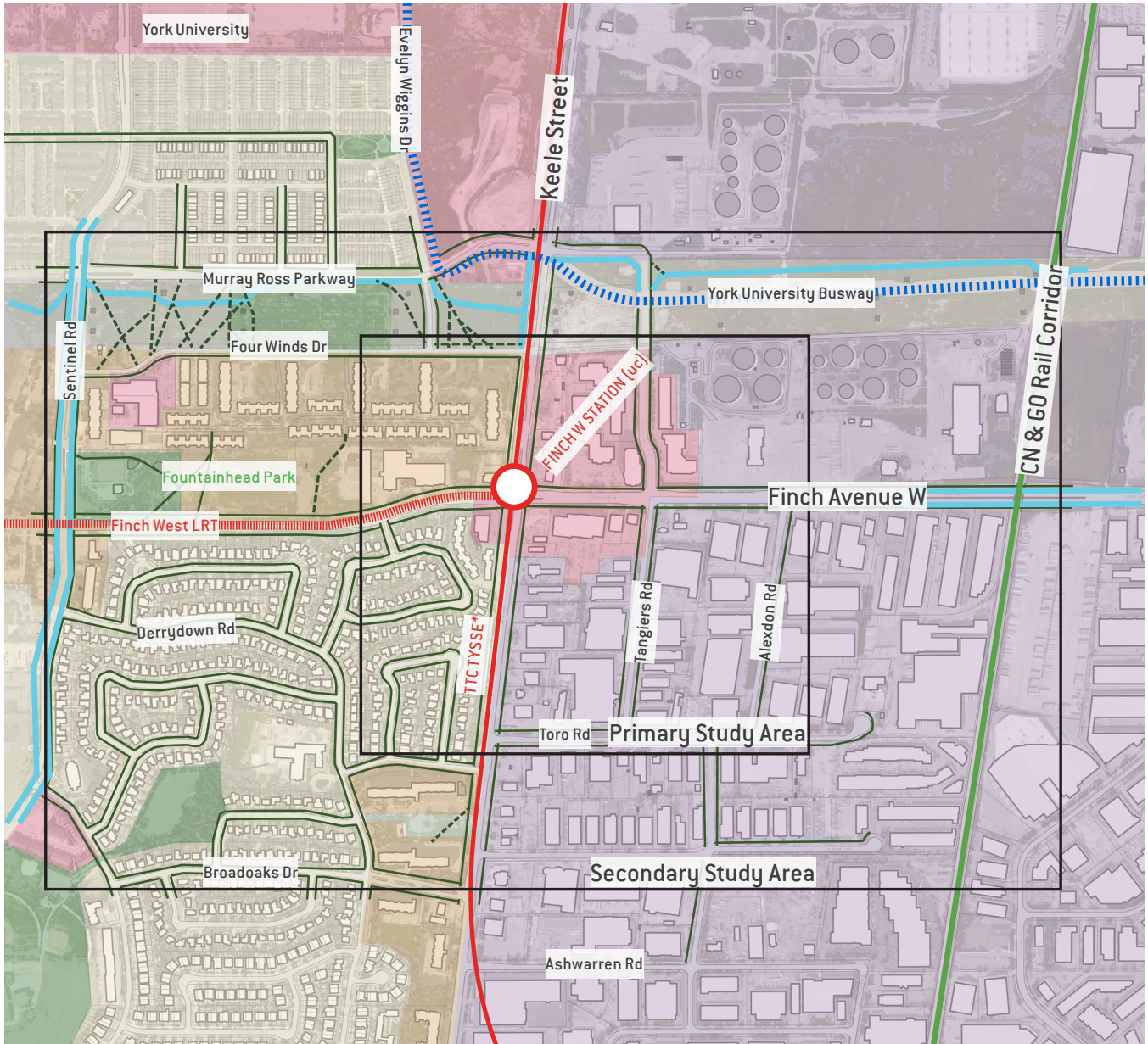

MAP OF EXISTING CONDITIONS

Land Uses	Existing Features	Existing Features
Residential	Subway	Sidewalks
Residential Apartment	LRT	Informal pedestrian routes
Commercial	York U Busway	Bicycle Infrastructure
Utility & Transportation	GO Train	
Parks / Open Space	Study Areas	
Employment Industrial	Keele/Finch Transit Hub	

TWO // the public realm

2.1 Improving the Public Realm

The context of DUKE Heights is changing. Mobility choices are being enhanced, development will intensify, and the public realm will change. Given the proximity to high order transit, York University, residential neighbourhoods, and over 2,500 businesses, the area has the opportunity to become a significant urban centre.

This document sets out suggestions for improvements to re-balance streets to ensure adequate space is given to all user groups.

The public realm network is highly animated by the people who walk from place to place and interact with the uses along the streets and within the adjacent buildings. The public realm network and its relationship to adjacent buildings is fundamental in establishing the quality of place that will make an area attractive to investors and businesses. Further, it is crucially important to recognize the public realm's contribution to city-building as an economic imperative. A high-quality public realm network has tremendous economic value in terms of real estate value, and assessment value—that needs to be continuously enhanced through public sector investment. Experience has shown that the economic benefits of public sector investment in the public realm are desirable and achievable.

DUKE Heights is generally homogenous in its built form and public realm appearance. Land uses across the entire BIA are limited to Employment, Mixed Use, and Parks and Open Spaces, with the great majority being Employment Area.

The Employment Area consists almost exclusively of low rise structures sitting on large lots with generous setbacks. Streets are designed for vehicles, with little to no attention to other users. This is exemplified on streets where sidewalks either do not exist, or only flank one side of the street.

As mentioned, the BIA will be serviced by high order transit in the form of several subway stops along the new Toronto York Spadina Subway Extension as well as the new Finch West LRT. The BIA is also serviced by several bus routes and the GO Train which runs parallel to Keele Street and has a York University stop at the far eastern end of Canarctic Drive east of the campus.

Also notable is the expanding application of bicycle infrastructure including separated bike lanes along Finch Ave West, connections to the new transit hub along Keele, and connections to the network around the York University Campus. Although momentum is evident, the network of bicycle infrastructure is lacking, and requires serious consideration in this process.

Parks are non-existent in the BIA beyond a Reservoir that accommodates cricket pitches, and Fountainhead Park immediately west of Keele St at Finch Ave. W beyond the BIA boundaries. Open spaces consist of remnant properties, and right-of-ways such as the hydro corridor that accommodates the York University Busway, as well as the Finch Hydro Corridor Recreational Trail.

The adjacent plan demonstrates that there is a significant permanent residential population immediately west of the BIA, as well as York University, and its associated housing immediately northwest of the BIA. These two areas, as well as the burgeoning commercial activity along Finch further qualify and necessitate the need for an improved public realm.



Streets should be designed to account for all users

2.2 Economic Benefits of Public Realm Investment

Investment in the public realm is good for a city's image, health, quality of place and quality of life. This investment is also good for the bottom line. Investment in the public realm helps to ensure that new jobs are created, commercial and business centres are enhanced, property values are increased and income is generated for investors for many years to come.

The concept of economic benefits realized through public realm network investment is being heard in progressive cities across North America. Numerous studies have shown that significant public investment in the public realm network can:

- Promote increased property values and tax assessment: A healthy retail sector dramatically enhances the economic benefits through the collection of HST. Enhanced property values enrich property tax assessments. An improved overall environment attracts more residential development. Increased residential density increases the residential property tax base.
- Promote reinvestment by the private sector in old and new building stock: Experience across North America indicates that public sector investment stimulates private sector investment. Creating a beautiful public realm is an investment in the future. Public dollars spent secure existing tax revenues and have the potential to generate tremendous additional financial returns to all levels of government.
- Maintain existing businesses and attract new businesses: Success breeds success, and an enhanced public realm ensures the retention of current tenants and attracts new businesses. Public investment sends a strong message to the private sector.

Overall, investment can be leveraged into private sector investment response and long-term economic prosperity. Public sector investment is required as a key stimulus to enhance the demand for development (influencing the market) by investing in the city, which, in turn, will establish the appropriate environment for revitalization and investment.

There is an opportunity to implement the improvements through the development process. This Public Realm Design Report provides guidelines to direct enhancements to the public realm and to streetscapes for coordinated development over time.

3.1 Vision

The DUKE Heights BIA strives to instill civic pride, local stewardship and an urban vitality unique to this important employment area through increased investment in the public realm.

THREE // vision & principles

3.2 Guiding Principles

Establish the Gateway

The intersection of Keele and Finch will be the primary gateway to the DUKE Heights BIA, as well as serve as the terminus of the Finch West LRT. The approach from the west is vital with respects to the visual identity of this intersection and the BIA as a whole. Therefore, the median treatment extending from the LRT portal immediately east of Romfield Lane extending halfway to Tangiers Road, east of Keele Street, will be treated with the same design intentions and elements. The block from Keele Street to Tangiers Road will include recommendations for a large scale public art gateway feature that will be a strong visual identifier for this evolving district.



UBC Gateway Feature. Vancouver - BC

Balance of Users

The interface between pedestrians, cyclists, and vehicles is critical to ensure a safe comfortable public realm for all users.

Street design should encourage active transportation and public transit to help people live healthier, happier, and more sustainably. An improved pedestrian and cyclist realm, with wider sidewalks, furnishing zones, separated bike lanes and place-specific lighting are all aimed at encouraging a safer and more accommodating environment for all user groups. It should be a place where users will not only pass through, but linger and/or gather in a renewed civic space that prioritizes the pedestrian and cyclist experiences and accommodates efficient travel by transit and automobile.



King Street - Kitchener ON

Establish Consistent Design Quality

In order to establish a consistent palette of materials and furnishings, the consolidation of streetscape elements must be achieved and implemented.

A strong identity is important for special districts. A contiguous streetscape design and family of streetscape elements can help cultivate a sense of place by creating a consistent, attractive image.



Copenhagen - Denmark

Establish a Green Foundation

As a critical component to an improved public realm, the establishment of a consistent and sustainable urban tree canopy is vital. Planting and landscaping in the form of trees, shrubs, perennials, grasses, and other groundcoverings enhance streetscape aesthetics.



San Francisco - CA

Cultivate a Vibrant Street Life

Streetscape and public realm design should encourage people to consider streets as places to go and spend time, as opposed to being exclusively conduits for movement. Busy spaces are more attractive and safer and more inviting than sparsely populated ones.



Stimulate Private Investment

Streetscape improvements play a strategic role in economic development and have the capacity to alter patterns of economic activity. Investment in the public realm demonstrates to the business owners and the public that the BIA and the City are taking a leadership role in community revitalization which will foster community stewardship and subsequent private investment.



Establishing the Brand

In order to establish DUKE Heights as a unique BIA, the implementation of a consistent and uniform branding strategy is crucial.



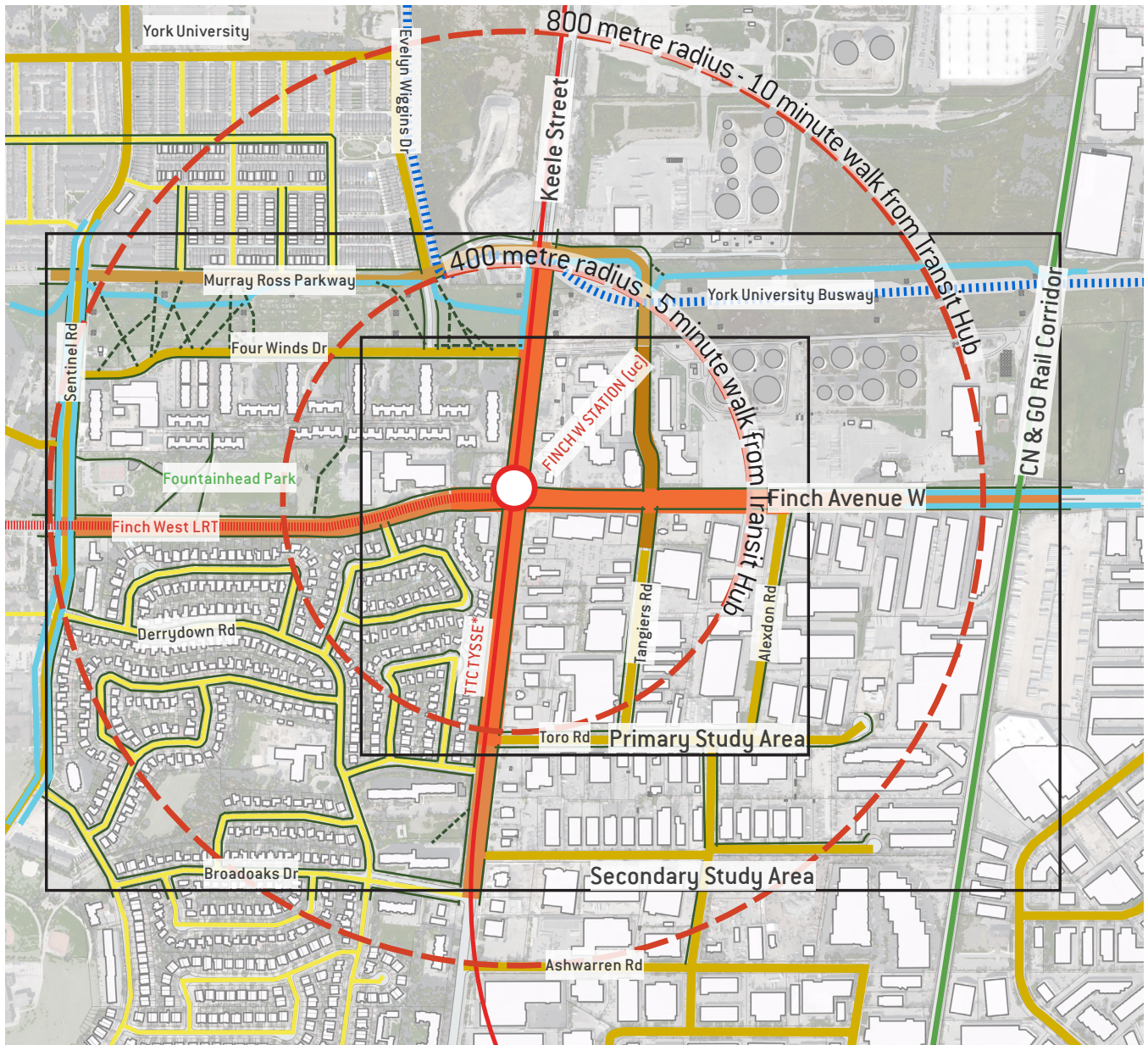

MAP OF CIRCULATION FEATURES

Street Type	Existing Features
Major Arterial	Subway
Arterial	LRT
Major Collector	York U Busway
Medium Collector	GO Train
Collector	Study Areas
Local	Keele/Finch Transit Hub
	Sidewalks
	Informal pedestrian routes
	Bicycle Infrastructure

FOUR // design elements

4.1 Balance of Users

The interface between pedestrians, cyclists, and vehicles is critical to ensure a safe comfortable public realm for all users.

The network of streets shown in the Primary and Secondary Study Areas illustrate a hierarchy that is proposed to both increase efficiency and create more comfortable, safe and appealing walking and cycling conditions.

Pedestrians

All streets will be flanked by street trees and seasonal planting, well-lit to improve safety and security, and will provide wide and comfortable pedestrian zones to encourage and enhance walking.

Sidewalks shall be no less than 2.1 metres, and transition seamlessly into adjacent edge zones, which would define the edge of the public realm and the adjacent flex zones/setbacks.

Cyclists

Bicycle infrastructure will be provided to ensure the safe and efficient circulation of cyclists throughout

the Study Area. Bicycle lanes will be encouraged on primary circulation routes and where safety concerns exist, and sharrows will be promoted on most other streets.

To ensure continuity and understanding, bike lanes shall be painted using current City of Toronto standards.

Transit

Transit plays an important role in the vitality of urban neighbourhoods, and the DUKE Heights Study Area will surround one of the City's newest mobility hubs. Beyond the significance of the hub, streets will be designed to balance the needs of surface transit uses with the safe movement of cyclists and pedestrians.

Motor Vehicles

Where feasible, motor vehicle lanes widths will be reduced to encourage a more complete street. Considerations will be made to ensure traffic flows will not be adversely affected.



College Street - Toronto ON

Parking

A key objective is to promote walkability within the DUKE Heights Study Area. However, it is crucial to recognize that the community will also be accessed and serviced by vehicles. To this end, how parking is accessed and where parking is located in relation to a building or a site will be an important design consideration so as to not undermine the urban design objectives for Centre Street. All parking should be accommodated either on the street, in parking areas located at the rear or side of the building, or below or above ground.



4.2 Consolidation and reorganization of streetscape elements

A coordinated family of street furniture presents the opportunity to establish a cohesive visual connection and identity across streets and public spaces in the Study Area. Street furniture includes benches, waste and recycling receptacles, and bicycle racks. These elements enhance the pedestrian experience by contributing to users' sense of comfort and safety. They also signal that streets are places to rest, reflect, and socialize.

Paving

The choice of paving materials for the sidewalk and amenity zones represents an opportunity to enhance the pedestrian experience. Paving helps to define spaces and their intended use.

The application of the City of Toronto standard unit pavers in charcoal grey shall be applied in all furnishing zones.

Cast-in-place concrete sidewalks will be the surface treatment for pedestrian clearways. Custom jointing patterns are recommended on primary streets and will be applied with custom jointing patterns



Furnishings

DUKE Heights will implement a collection of selected furnishings from the City of Toronto Coordinated Street Furniture collection and Streetscape Manual.

Benches

Benches encourage users to occupy a space rather than simply move through it. Seating provides a place where people can rest, socialize, read, people-watch and generally linger.

Benches are to be situated on streets where there is a higher volume of pedestrian traffic, as well as in areas where people are encouraged to linger, such as open courtyards, and plazas in proximity to transit stations.



City of Toronto Bench

Litter & Recycling Receptacles

Providing quality waste and recycling receptacles is of important in keeping the streetscapes clean. These elements must be frequent enough that people use them willingly yet minimal enough that they do not impose upon the character of the street. They should be simple to use and should discourage animals from entering them.

Litter recycling receptacles should be located in close proximity to seating areas and high volume pedestrian areas.



City of Toronto Litter & Recycling Receptacle

Bicycle Parking

Bicycle Parking is a critical element in promoting a healthy and sustainable community. Parking elements need to be sturdy yet unimposing and the design must allow for easy locking accommodating different lock styles and bicycle styles. Bicycle rings are to be located within the furnishing zones.



City of Toronto Bike Ring

Info boards & Wayfinding

Wayfinding includes the visual cues that individuals use to navigate in unfamiliar surroundings. A wayfinding strategy is of great importance for orienting pedestrians from transit stops and parking areas. While much of the urban design framework contributes to and reinforces one's orientation to the area, such as locating landmark architectural treatments, public art and gateways, a coordinated and legible wayfinding strategy should also be implemented to strengthen connectivity. Of particular assistance to visitors are graphic communications, including street signs, directional signage and maps.

Public wayfinding and information boards provide an allocated space for advertising, neighbourhood bulletins, and important information for visitors to navigate the neighbourhood.

Publication corrals

Newspaper boxes and other similar publication boxes vary in colour and size, and often contribute to visual pollution and a cluttered streetscape.

These boxes will be consolidated into publication corrals and should be located at intersections in highly visible locations.

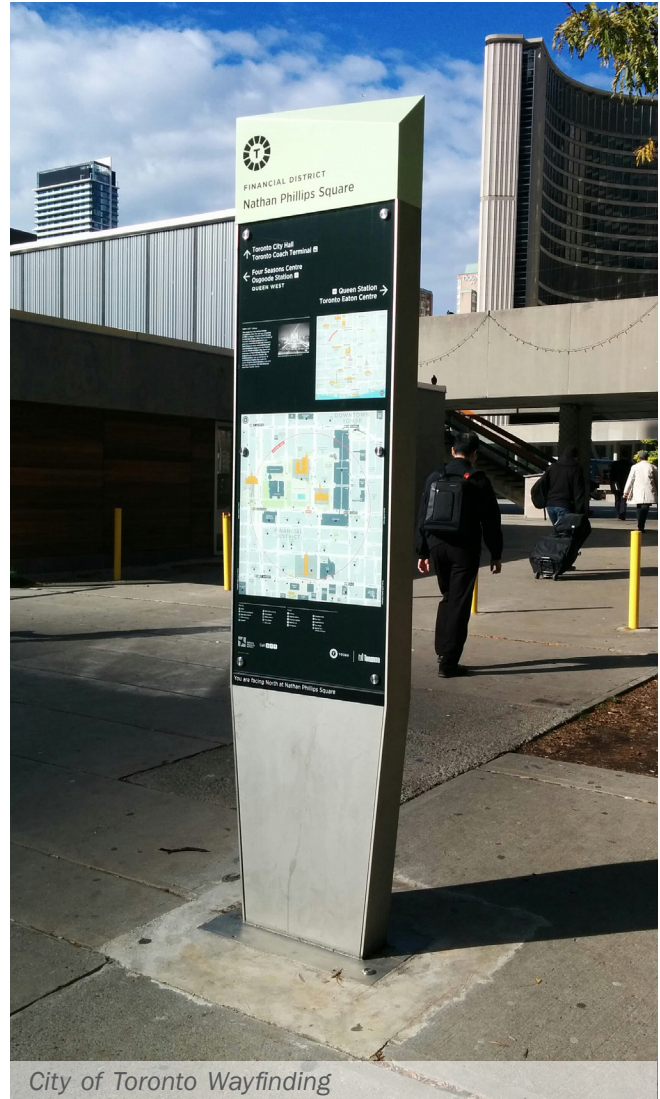

City of Toronto Wayfinding



City of Toronto Newspaper corral



City of Toronto Newspaper corral

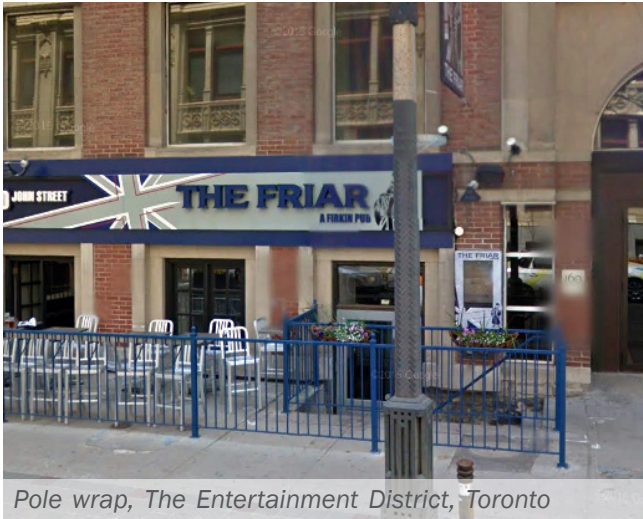

Pole wrap, The Entertainment District, Toronto

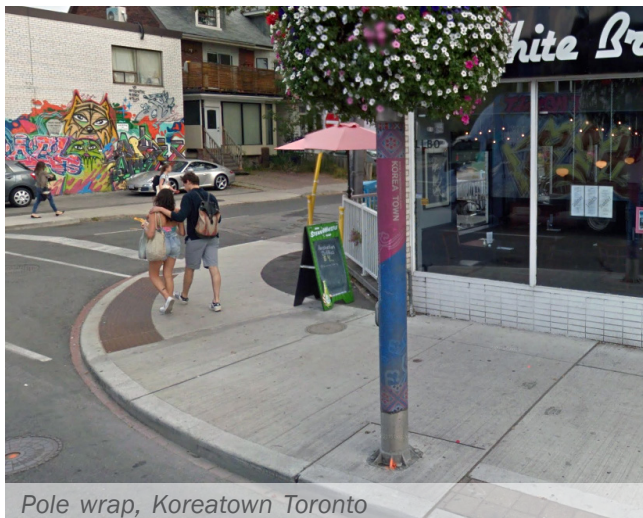

Pole wrap, Koreatown Toronto



Pole wrap, Greektown Toronto

Street poles / Message centres

Street poles, light standard poles, parking signs and others are common elements found on streetscapes. Although necessary, they often clutter the public realm. If burying hydro is out of the question, it is recommended that poles and signage be consolidated and coordinated.

Street poles are also often used for posting bills and advertisements. To discourage such activity, as well as provide visual appeal and consistency, the application of pole wraps is encouraged.

To allow for the continued application of bills and public notices etcetera, the provision of Public Message Centres are encouraged at major intersections and pedestrian gathering areas.



City of Toronto Public Message Centre

Lighting

Lighting contributes to a greater urban environment by extending the life of a street beyond work hours. All too often, however, city streets are lit for the benefit of motorists, while ignoring the sidewalk. Appropriate design and application of lighting can help to privilege the scale and experience of pedestrians. It is suggested that the Lumec Capella light standard be used on Major Arterials, Arterial, and Major Collector streets.

- 'Capella' Fixture by Philips Lumec to be used for street lighting
- Pedestrian lighting is to be 'Capella' fixture by Philips Lumec
- Pedestrian lighting fixtures and arms are to be installed on street lighting poles on Major Arterials, Arterial, and Major Collector streets.
- Provide electrical conduit through open planting zones in order to accommodate seasonal lighting;
- All lighting poles and standard poles shall include custom base as indicated in furnishing appendix;
- Provide feature up-lighting below trees on Major Arterials and Arterial streets;
- Lighting shall take into account 24-hour site use, with particular attention given to creating safe, well-lit pedestrian routes, with a finer grain of illumination for the common-use outdoor areas.
- Provide electrical outlets on the street light poles, at the base of the trees and for the digital information boards;

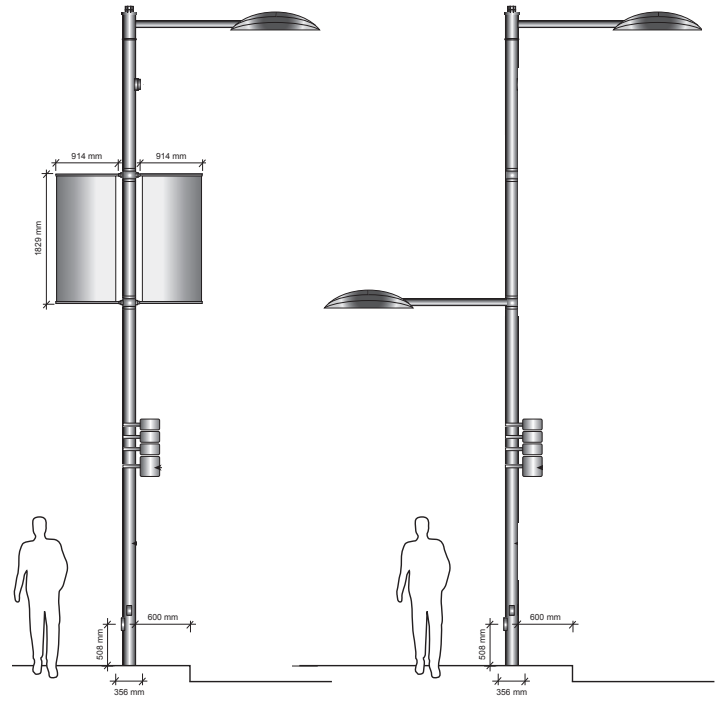

City of Toronto Light Standard



The Lumec Capella light in Markham ON



Branding on banners

4.3 Establishing the Brand

In order to establish the DUKE Heights BIA identity, the implementation of a consistent and uniform branding strategy is crucial. The evidence and efforts exemplified through this branding strategy will speak volumes, and accelerate consumer and investor interest in the district.

- Street light, hydro and signal poles shall include a minimum 2.5m anti-graffiti sleeve that includes DUKE Heights branding and colours.
- Provide branding on banners, newspaper corrals, decorative protective tree fencing, etc.
- Provide a large scale public art gateway feature on the median immediately east of the intersection of Keele Street and Finch Avenue West on Finch that properly represents this important business district;
- Provide a complementary public art gateway feature on the median on the west side of Keele Street;
- Provide the required structural base to accommodate the weight of the gateway feature in the median.
- Ensure gateway art feature includes the DUKE Heights branding;

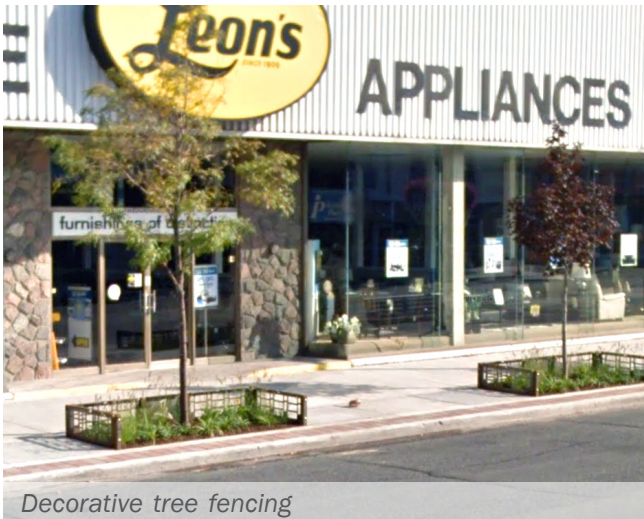

Decorative tree fencing

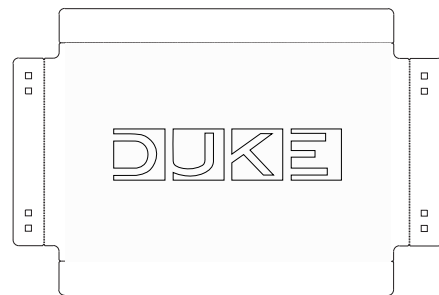

Branding on decorative tree fencing

4.4 Greening the Public Realm

As a critical component of an improved public realm, the establishment of a consistent and sustainable urban tree canopy is vital. In the GTA and throughout North America, the average downtown street tree survives for only 7 years. One of the primary reasons for this is the low volumes and highly compacted nature of soil inherent to development. To overcome problems associated with low soil volumes, compacted soils, and limited root growth capacity, soil volumes that meet or exceed City standards are required throughout the Study Area. This will significantly contribute to street tree growth and longevity.

In order to achieve the minimum soil volumes outlined in the City of Toronto Urban Design Streetscape Manual - Guide to Standard Planting Options (see appendix), there are several techniques that will be applied in DUKE Heights.

Fortunately, street right-of-way design throughout the Study Area has been afforded wide grass boulevards that can easily accommodate the addition of new plantings far beyond the required minimum soil volumes.

In cases where there is limited space and/or higher volumes of pedestrians such as on Major Arterials, Arterials and at intersections, it is recommended that soil cells, structural soil, and/or concrete bridging are applied below the surface to accommodate necessary soil volumes.



Tree and grass plantings in boulevards - Calabasas CA



Wide boulevards - Tangiers Road

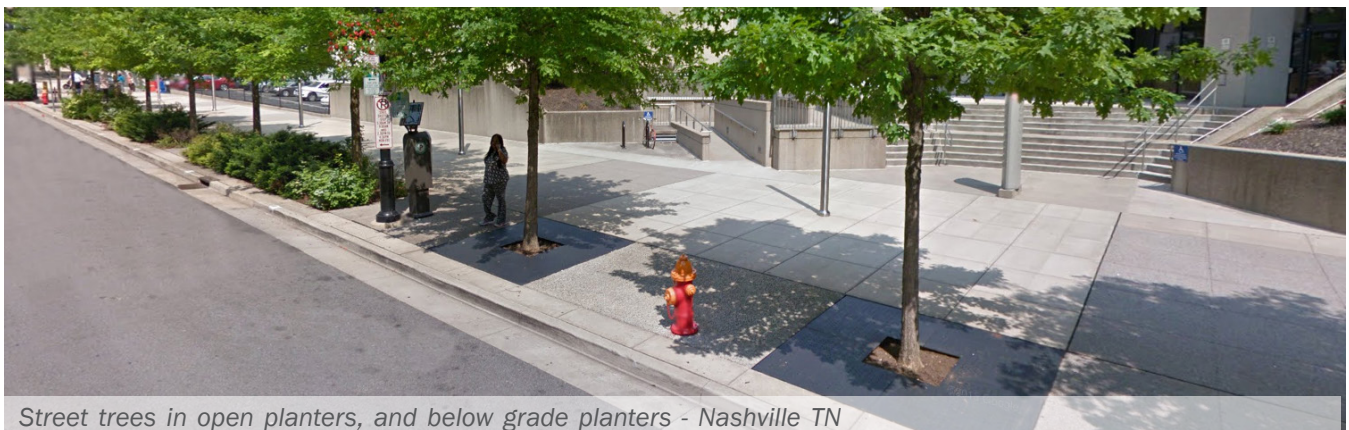

Street trees in open planters, and below grade planters - Nashville TN

Structural Soils

Structural soil is a mixture of soil and stone, or soil and a derived aggregate, such as expanded slate or shale. Structural soil is used to accommodate the structural requirements for sidewalk design and installation while permitting root growth. Compositions of gap-graded gravels, clay loam, and a stabilizing agent to keep the mixture from separating can range in ratio for different applications.

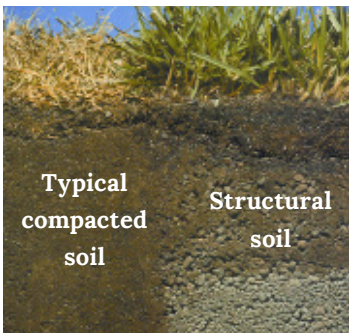

Structural soil allowing uninhibited tree root growth

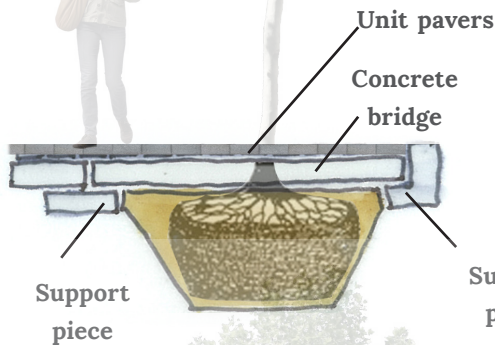

Concrete Bridging

A structural pavement surface or subsurface spans between supporting ends over the growing medium trench.

- ‘Bridge’ can be reinforced precast or cast-in-place concrete panels.
- Supporting ends can be designed to accommodate tree grates.

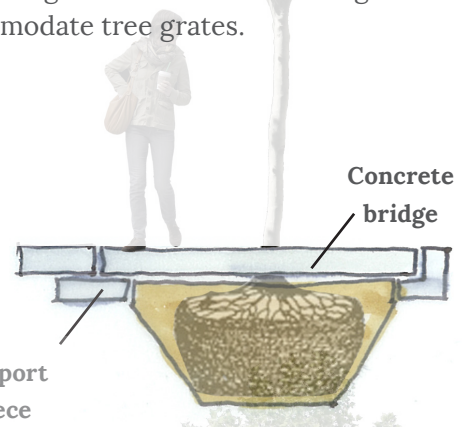

Soil Cells

Soil cells are modular systems that range in shape and size. The surface treatment can be built directly on top of these support structures, which also provide ample room for root growth and soil volumes.

- Modular system options include Silva Cells (Company: Deep Root), and Tree Root Protection: (Company: Cupolex-Rialto)

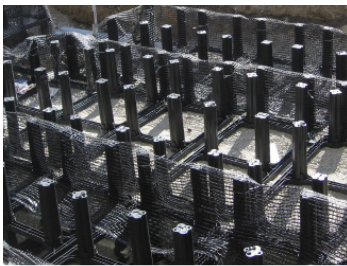

Structural soil cells during construction

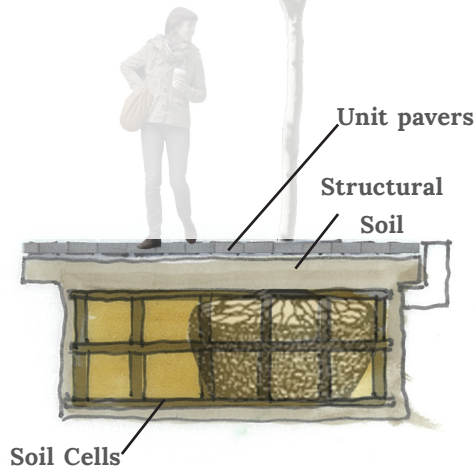

Open Planter

Where space permits, an open planter is the most cost-effective method of achieving the recommended soil volumes.

- Provides an opportunity for shrub, and perennial plantings.
- Allows free drainage of runoff

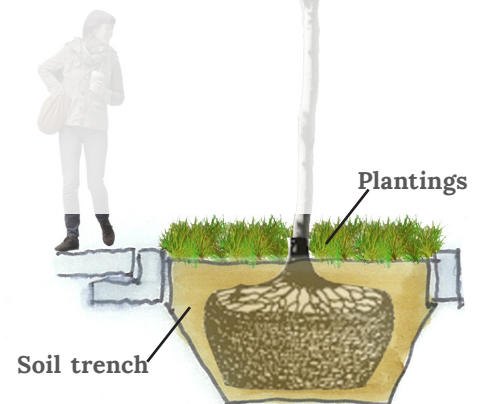

Further greening strategy requirements include:

- Trees shall be planted at a maximum 8 metre interval along both sides of the street;
- In order to achieve a healthy urban forest condition that is resilient to biotic (ie. pests and pathogens) and abiotic (ie. salt and temperature extremes) influences, species selection shall consist of a mix of native deciduous species with no single variety exceeding 25% of the total;
- Trees shall be planted in open planters, unless located within 18 metres of an intersection, where they would otherwise be planted within a tree grate;
- Trees shall be planted in a single row along all medians at a 8 metre spacing provided City of Toronto standard soil volumes are achieved;
- Planting beds shall be planted with native ornamental grasses that provide a range of seasonal textures and colours. These expanded planting areas also detain storm water through infiltration, reduce the volume of water entering the stormwater system, and lessen the discharge of pollutants into local water bodies during storms;
- Irrigation shall be included for all planting areas.



Tree Fences

In order to protect the plant material in open planters in areas of higher pedestrian volumes and adjacent to bike lanes, decorative tree fences are promoted. In order to accommodate this feature, there must be adequate sidewalk room.





Trees in grates - Montreal PQ



Buffered parking - Toronto ON

Tree Grates

Where soil volumes are achieved through the application of soil cells, structural soil, and/or concrete bridging, there is an opportunity to introduce tree grates where trees penetrate through the surface. Tree grates are an important yet often overlooked streetscape accessory. First and foremost they must be functional, allowing for water infiltration as well as space for trunk growth. This is in conjunction with preventing the treepit from collecting garbage. On top of functionality, the grate should also be attractive and fit coherently with the other elements in the streetscape family.

Greenways

The York University Busway runs along a hydro corridor at the north end of the Study Area which bisects the entire BIA. This “greenway” has the potential to not only act as an important recreational and circulatory route for cyclists and pedestrians but also an important linear green corridor that is treed and/or planted with grasses and seasonal plants. The greenway can connect parks, streets and neighbourhoods, and can serve as wildlife habitat.

Surface Parking Buffers

Many roads throughout the study area consist of surface parking lots immediately adjacent to sidewalks. This creates an unsafe and unappealing pedestrian environment. To mitigate the feeling of exposure, buffer planting is recommended in these cases. The scale and extent of these buffers will vary and may be comprised of trees, shrubs, planting beds, swales (which may include bio-retention), and pedestrian pathways.

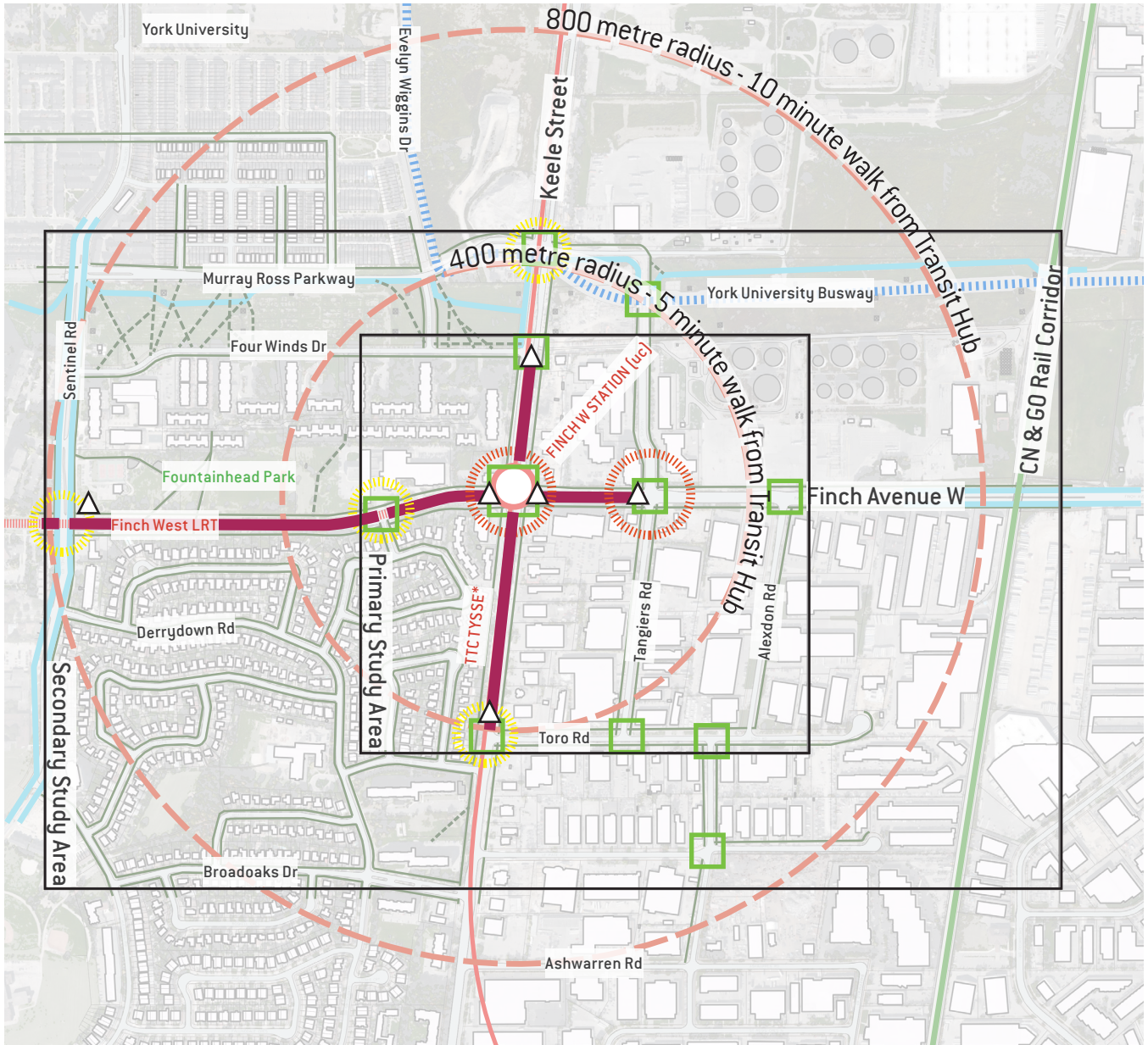

MAP OF SPECIAL FEATURES

- | Special Features | | Existing Features | | | |
|------------------|------------------------|-------------------|-------------------------|--|----------------------------|
| | Public Art Locations | | Subway | | Sidewalks |
| | Major Gateways | | LRT | | Informal pedestrian routes |
| | Minor Gateways | | York U Busway | | Bicycle Infrastructure |
| | Medians | | GO Train | | Study Areas |
| | Enhanced Intersections | | Keele/Finch Transit Hub | | |

4.5 Special Features

Public Art

Public Art provides an opportunity to enhance community identity and civic pride, orient visitors and celebrate local talent. Possible public art sites are identified throughout the Study Area and generally correspond to prominent public realm locations such as View Terminus Sites, Gateways and/or key intersections.

Gateways

Clearly defining gateway sites serves to signal key points of entry into the BIA, reinforces identity, and enhances orientation. While major Gateways are identified on either side of Keele St on the Finch Ave. median, minor gateways can also be considered at a number of other key entry points and intersections. Gateways provide opportunities to coordinate the design of open spaces, landscaping, signage, public art and architecture so as to create a clear sense of entry into distinct areas.

Median

Medians play an important role in the Study Area from both a safety and an aesthetic perspective. From a safety standpoint, the median provides a level of comfort when crossing wide roads. Aesthetically, the medians on Finch Ave and Keele Street provide a tremendous opportunity to add another green layer of tree and seasonal plantings along both thoroughfares. The median also allows for the provision of art features and gateway elements.

Intersections

Intersections are a special feature of the streetscape; they serve as gateways and offer opportunities for pedestrians to gather, as well as encourage convenient and safe pedestrian environments. The plan recommends well articulated street crossing points that are aligned with desired walking patterns and destinations. Well-articulated Crosswalks are identified for all signalized intersections within the Study Area at a minimum, and recommended for all other secondary intersections where all-way stop signs exist.

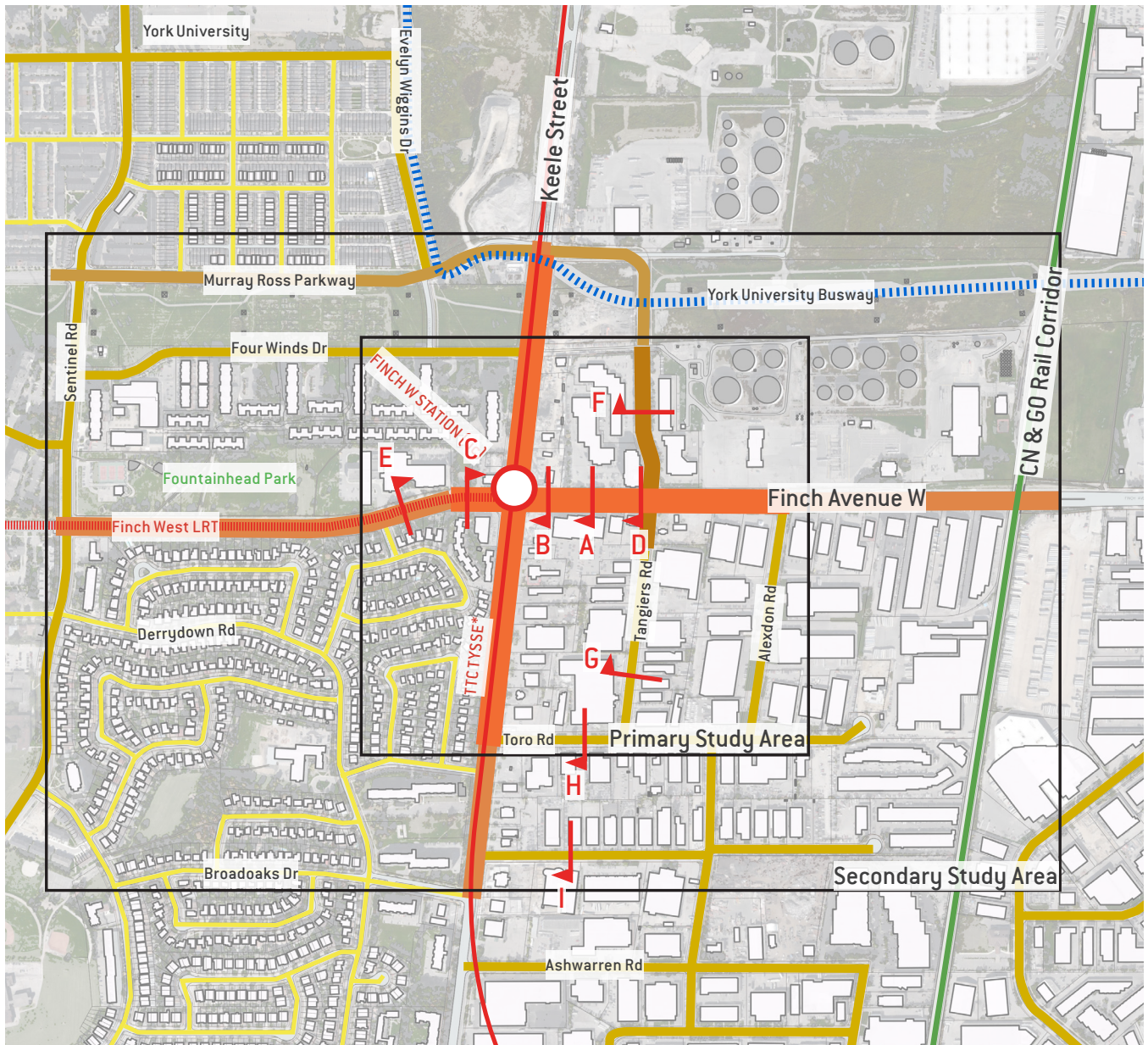

MAP OF STREET TYPOLOGIES

Street Type	Existing Features	Cross Section Locations
Major Arterial	Subway	Cross Section Locations
Arterial	LRT	
Major Collector	York U Busway	
Medium Collector	GO Train	
Collector	Study Areas	
Local	Keele/Finch Transit Hub	

FIVE // streetscape details

The following section outlines how to apply the various public realm components described in the preceding pages.

The street cross sections were selected as they demonstrate typical street conditions for the various street typologies within the Study Areas.

Although conditions vary from street to street through the Study Area, these streets provide a basis and rationale for how to apply streetscape improvements across all streets.

Streetscape improvements are recommended within the current street width condition, with no curb re-alignment being proposed.

General Guidelines to be applied to all street typologies:

- Restorations and commensurate enhancements to the public realm that will be primarily due to rebuilding of the public right-of-way resulting from the construction of the Stations and Stops to the current City of Toronto standards and guidelines.
- Coordination with the City of Toronto is required to ensure restorations of the streetscape is coordinated with City enhancement plans or local BIA initiatives and to provide a smooth, safe and seamless transition to unaffected existing areas.
- Installation of all existing BIA assets as well as any new ones that are supplied by City and shall provide infrastructure provisions including power that is required for operation is required.
- All public realm improvements shall be congruent with the City of Toronto Accessibility Design Guidelines.
- All furnishing recommendations are in line with the City of Toronto Coordinated Street Furniture collection from the Streetscape Manual.

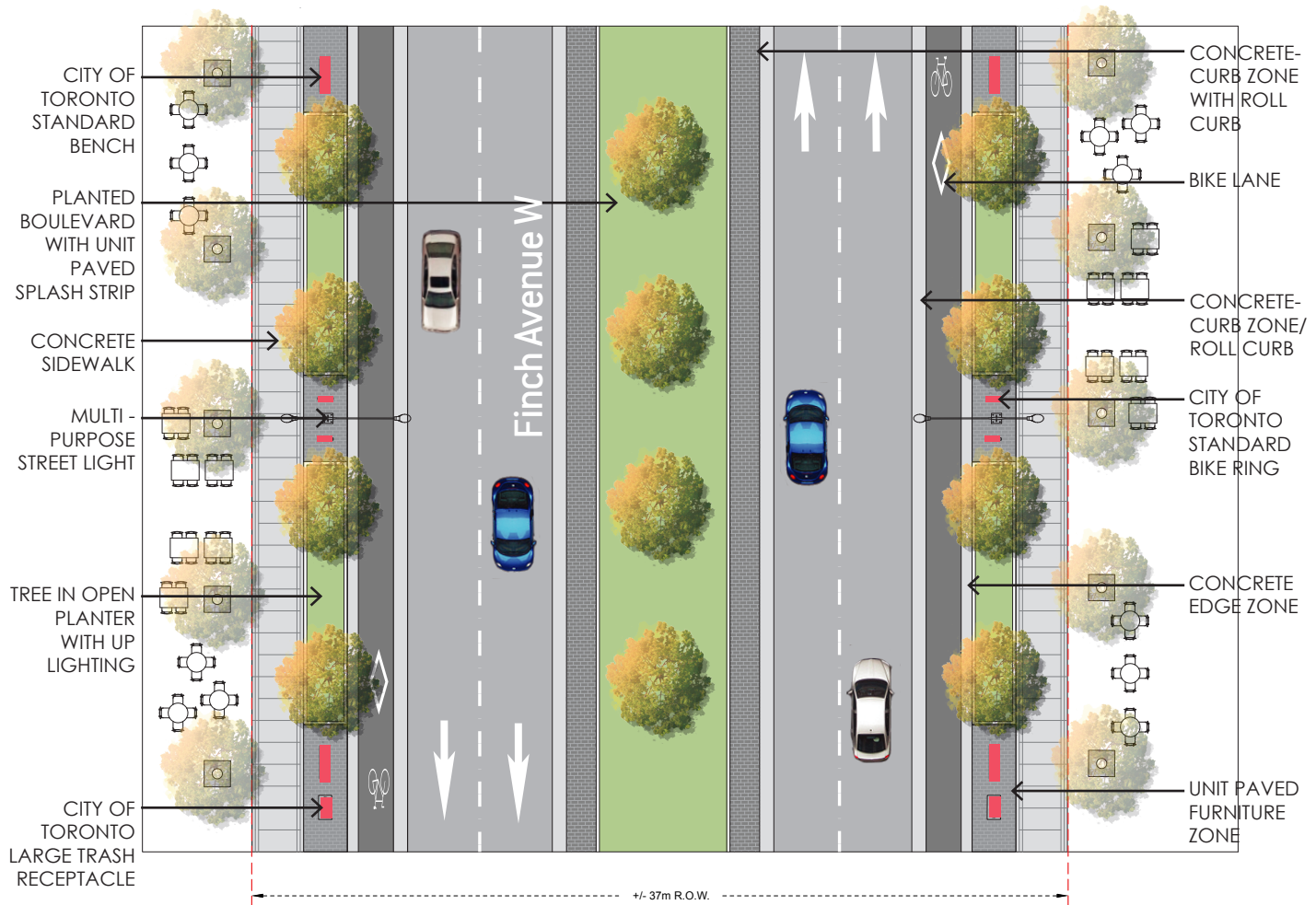
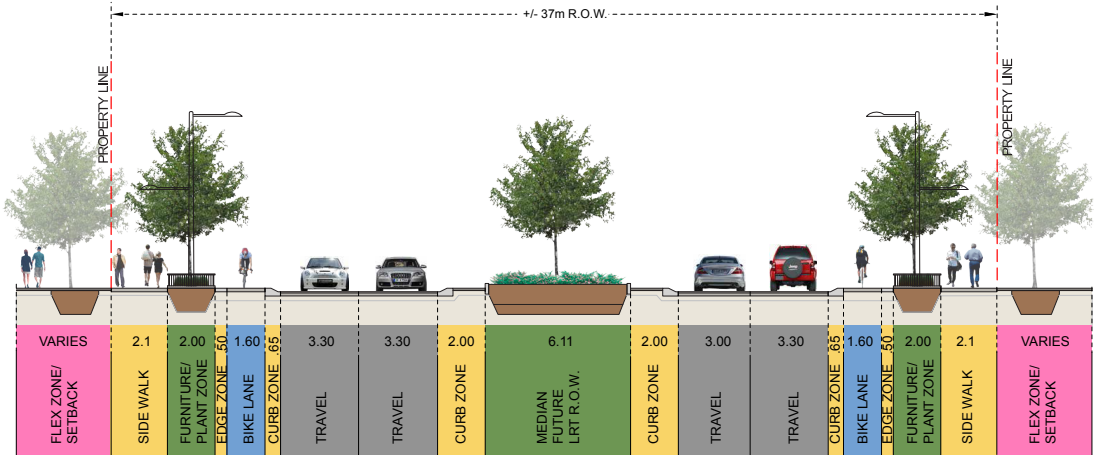

Major Arterial Type A - midblock Finch Avenue W - east of Keele Street

Description

The Major Arterial Type A applies to large thoroughfares with a central median and a large setback. This corresponds with the Primary Study Area, specifically in the vicinity of the Finch Ave. West and Keele St. intersection. Major Arterial Type A right-of-way widths vary from 36m to 45m.

Character

Type A Major Arterials are characterized by a vibrant urban setting complete with animated building faces on both sides of the street, broad sidewalks, and street tree plantings suitable for high pedestrian and vehicular traffic. Double rows of street trees where space permits planted within continuous soil trenches and covered with large, walkable tree grates. Street furniture includes pedestrian lighting, cycle parking and seating opportunities allowing pedestrians to have an inviting place to linger.

Features

Public Right-of-Way Features include:

- 15.0m-24.0m Boulevard within the Public Right-of-Way;
- Driveway entrances to be consolidated and narrowed to establish a safer more comfortable pedestrian environment;
- Bike lanes are at equal grade to the sidewalk, and separated from vehicular traffic by a .65m curb zone and separated from adjacent planting/furnishing zones with a .50m edge zone;
- Bike lanes at intersections where they are at-grade with vehicles shall be painted using current City of Toronto standards;
- 2.0m minimum planting/furnishing zone shall be paved using City Standard rectangular unit paver in charcoal colour or approved alternative;
- 2.1m minimum concrete paved sidewalk with custom jointing;
- Paving treatment on all four corners of the Keele Street and Finch Avenue West intersection shall be the same treatment,

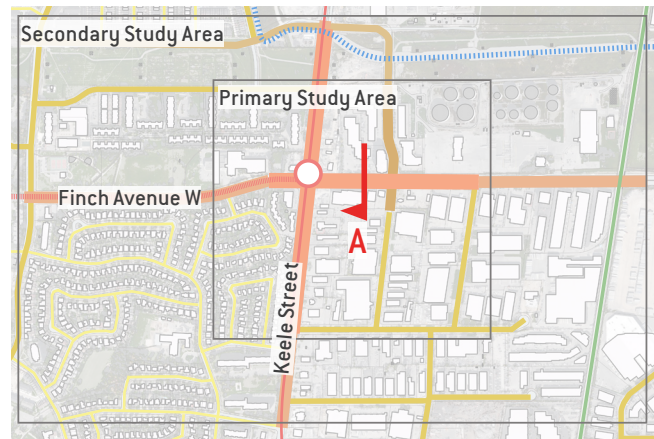

KEY PLAN

and be congruent with the TYSSE pattern as designed by Janet Rosenberg and Studio;

- Tactile Walking Surface Indicators at all corners as per City Standards;
- Consolidate and coordinate street signage to reduce visual pollution;
- Provide electrical outlets on the street light poles, at the base of the trees and for the digital information boards;
- Benches positioned facing the sidewalk within the furnishing zone at a consistent spacing of 15.0m;
- Backless benches within high traffic pedestrian zones;
- Litter recycling receptacles adjacent to every second bench, and at intersections and transit waiting areas within the furnishing zone;
- Multi-publication structures/corrals at intersections;
- Bicycle rings within furnishing zone in pairs adjacent to every second bench, alternating with litter receptacles;
- Public wayfinding and public message centres at intersections;
- Tree Fence to frame open planters adjacent to pedestrian clearway;
- Trees shall be planted at a maximum 8.0m interval along both sides of the street;
- Species selection shall consist of a mix of native deciduous species with no single variety exceeding 25% of the total;

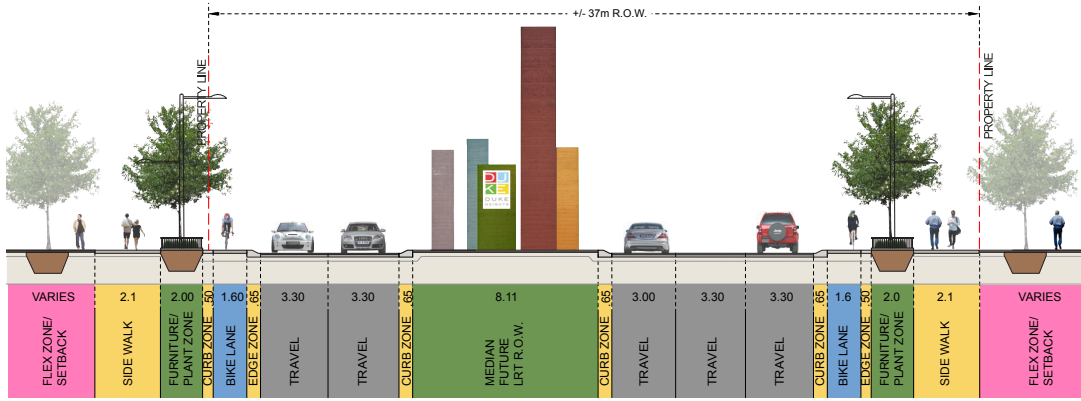

CORNER RADII IS SUBJECT TO CHANGE FOR MAXIMUM PEDESTRIAN AND BICYCLE SAFETY

WAY FINDING SIGNAGE

TREE IN TREE GRATE WITH UP LIGHTING

CITY OF TORONTO STANDARD BENCH

PLANTED BOULEVARD WITH UNIT PAVED SPLASH STRIP SKYLIGHTS

CONCRETE SIDEWALK

TREE IN OPEN PLANTER WITH UP LIGHTING

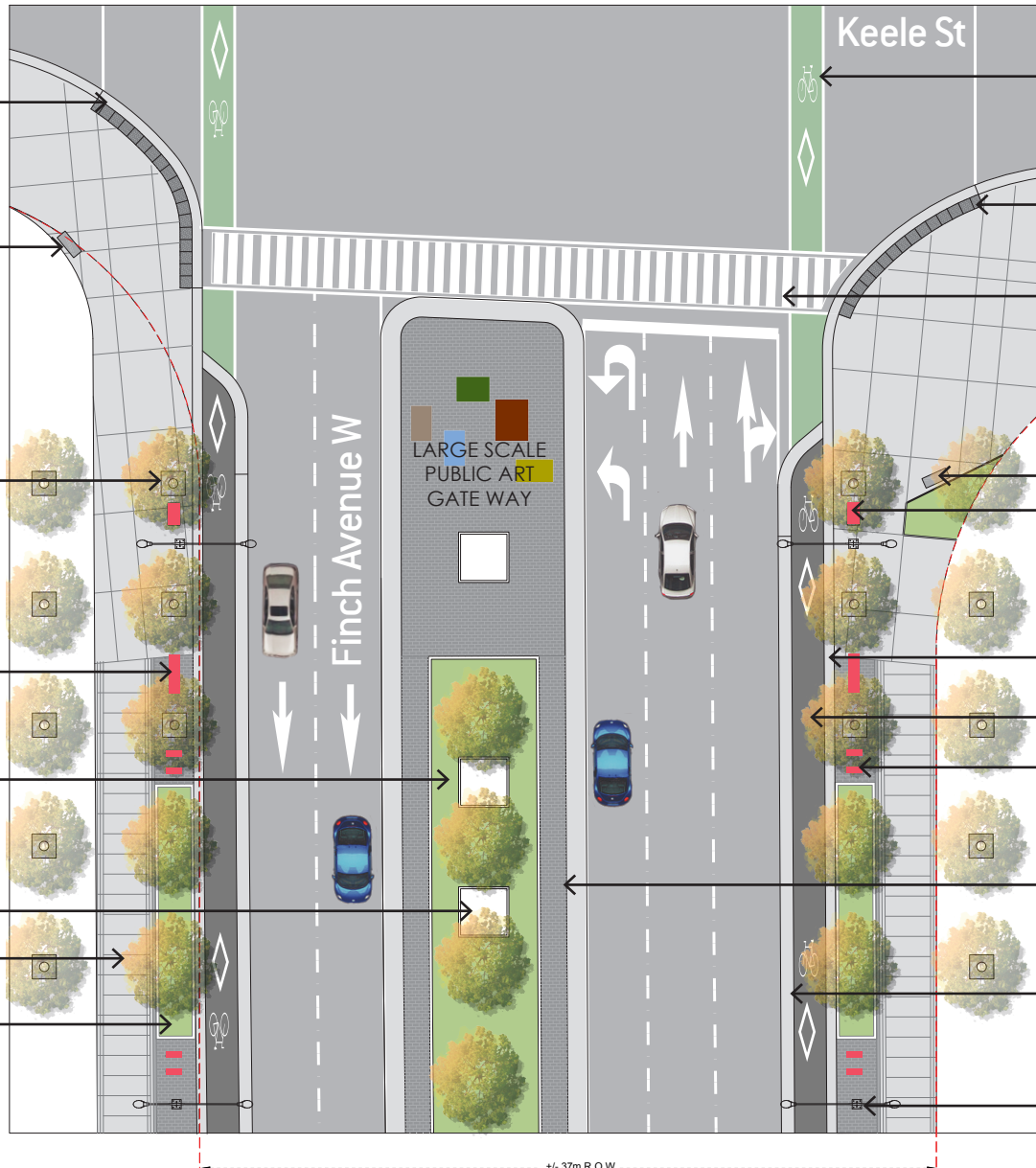

CLEARLY DEMARCATED BIKE LANE

DETECTABLE WARNING PLATES

CLEARLY DEMARCATED CROSSWALK

WAY FINDING SIGNAGE

CITY OF TORONTO LARGE TRASH RECEPTACLE

CONCRETE EDGE ZONE

BIKE LANE

CITY OF TORONTO STANDARD BIKE RING

CONCRETE-CURB ZONE WITH ROLL CURB

CONCRETE-CURB ZONE/ ROLL CURB

MULTI-PURPOSE STREET LIGHT

Major Arterial Type A Finch Avenue W at Keele Street intersection eastbound

Features cont'd from previous page

- Trees shall be planted within the City of Toronto standard soil volumes, accommodated if necessary through the usage of soil cells, structural soil, and or soil bridging;
- Trees shall be planted in open planters, unless located within 18.0m of an intersection, where they would otherwise be planted within a tree grate;
- Trees shall be planted in a single row along all medians that exceed 2.0m in width at a 6.0m spacing provided City of Toronto standard soil volumes are achieved;
- Planting beds shall be planted with native ornamental grasses that provide a range of seasonal textures and colours;
- Irrigation shall be included for all planting areas;
- Multi-purpose streetlight and pedestrian light poles shall be provided at a maximum spacing of 15.0m;
- Street light, hydro and signal poles shall include a minimum 2.5m anti-graffiti sleeve that includes DUKE Heights branding and colours;
- Provide electrical conduit through open planting zones in order to accommodate seasonal lighting;
- All lighting poles and standard poles shall include custom base as indicated in furnishing appendix;
- Provide feature up-lighting embedded in unit pavers below trees;
- Bury hydro lines, to allow for a less cluttered streetscape.

Setback Features include:

- Where setbacks afford a flex zone, paving surface treatment must be seamless;
- Where setback is greater than 2.0m, a second row of trees is encouraged;
- Flex Zone should be animated with cafes and/or other spill out commercial activity;

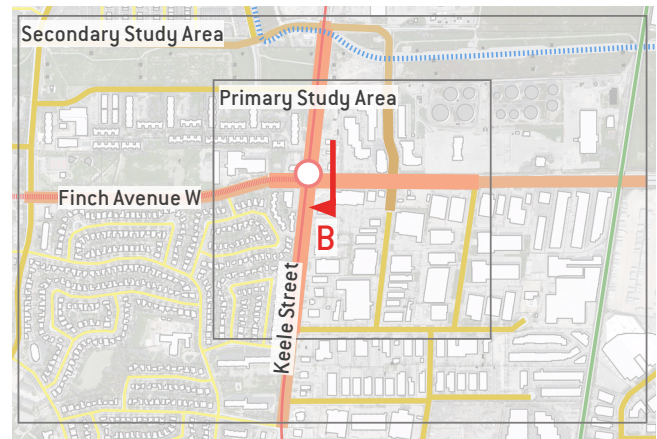

KEY PLAN

Median Features include:

- Provide power supply and irrigation to center median;
- Median shall include a unit paved curb zone, and plaza at intersection to accommodate a large scale public art gateway feature;
- Provide the required structural base to accommodate the weight of the gateway feature in the median.
- Light portals into the LRT station below shall be considered as an integrated/complementary feature to the large scale public art gateway feature;
- Ventilation and other structural and electrical components to be minimized and designed in such a way to impact public realm objectives as minimally as possible;
- Provide a large scale public art gateway feature on the median immediately east of the intersection of Keele Street and Finch Avenue West on Finch that properly represents this important business district;
- Ensure public art feature includes the DUKE Heights branding;

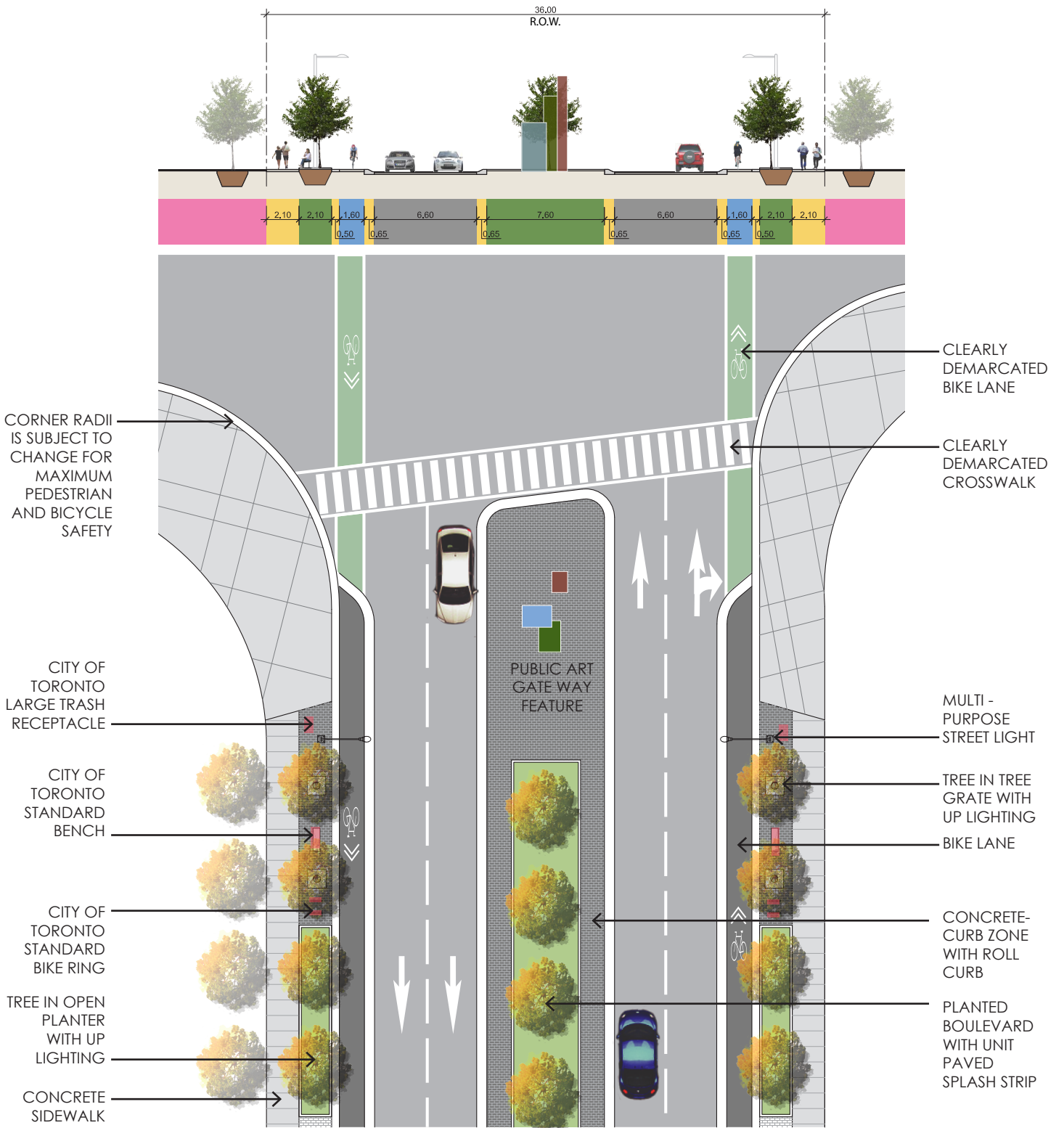

Major Arterial Type A

Finch Avenue W at Keele Street intersection westbound

Description

Please refer to preceding Major Arterial Description as it applies here.

Character

Please refer to preceding Major Arterial Character Description as it applies here.

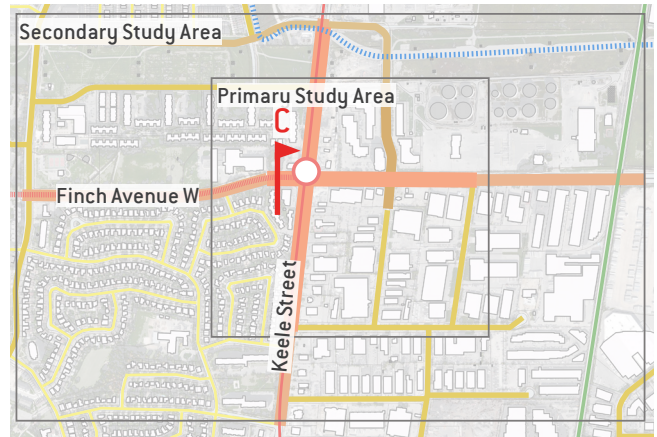

KEY PLAN

Features

Public Right-of-Way Features include:

- Please refer to preceding Major Arterial section as it applies here.

Setback Features include:

- Please refer to preceding Major Arterial section as it applies here.

Median Features include:

- Please refer to preceding Major Arterial section as it applies here.
- A complementary public art gateway feature will be positioned on the westbound median.
- Provide the required structural base to accommodate the weight of the gateway feature in the median.
- Light portals into the LRT station below shall be considered as an integrated/complementary feature to the large scale public art gateway feature;
- Ventilation and other structural and electrical components to be minimized and designed in such a way to impact public realm objectives as minimally as possible;

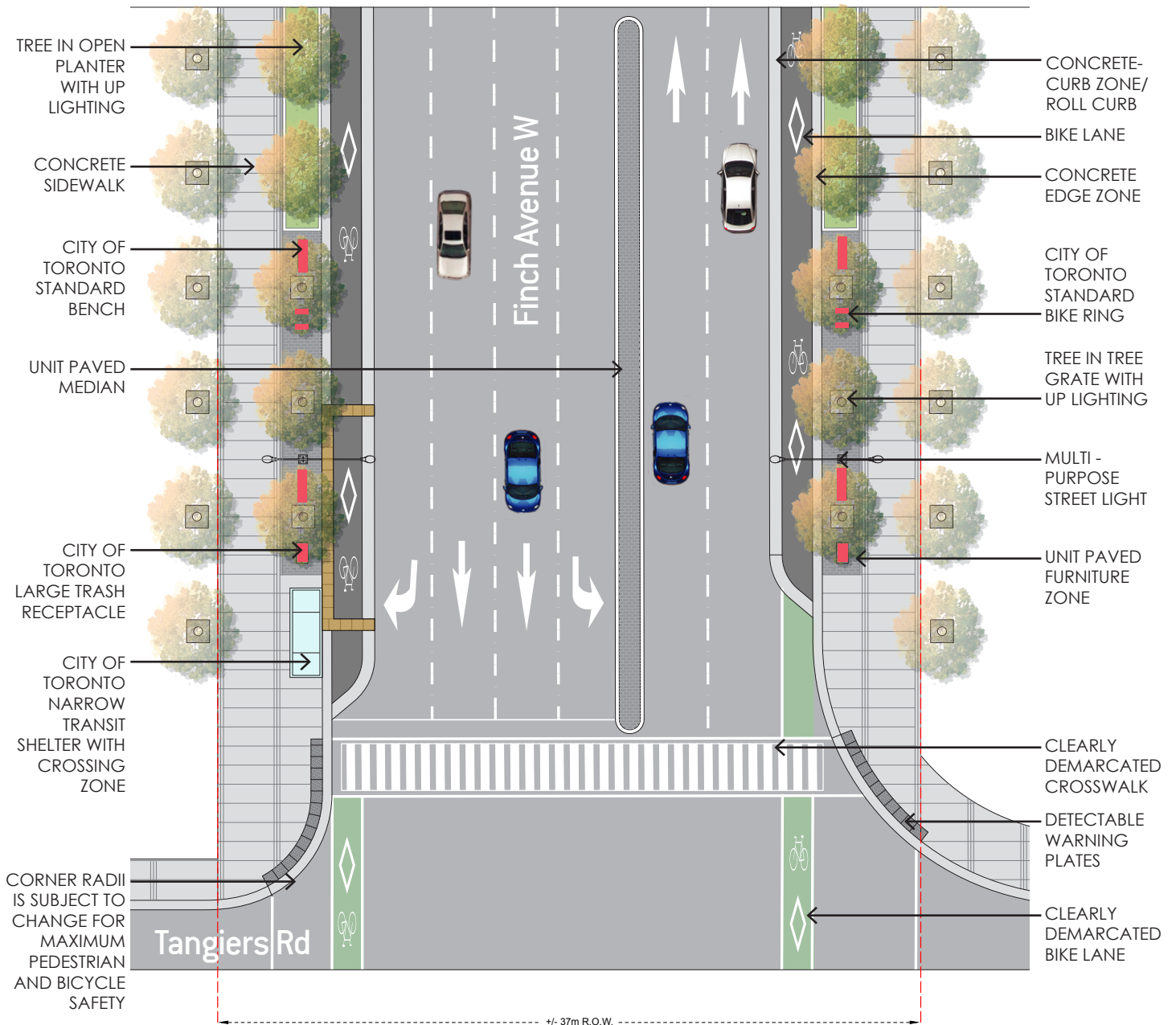
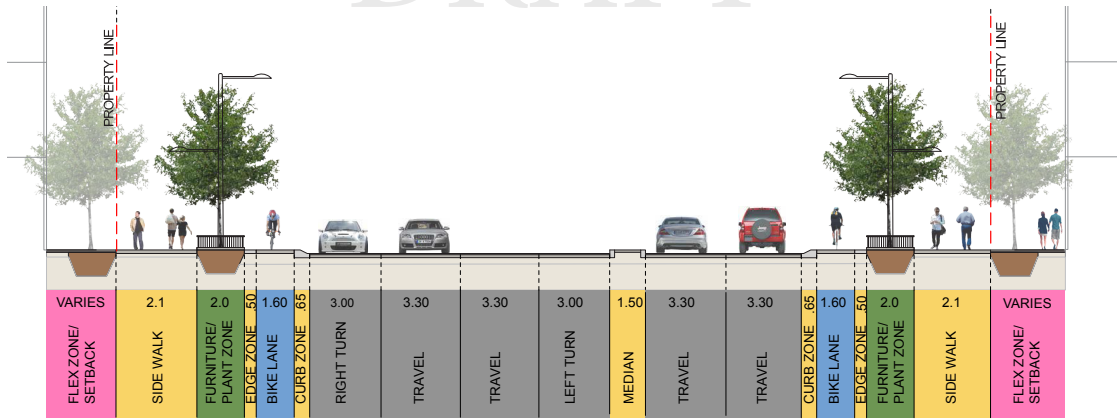

Major Arterial Type B

Finch Ave. at Tangiers Rd.

Description

The Major Arterial Type B is nearly identical to the Major Arterial Type A typology. Differences include a reduced boulevard width as a result of a narrower or non-existent median. This corresponds with the Primary Study Area and Secondary Study Area, specifically Finch Ave. West and Keele St. beyond the intersection. Arterial right-of-way widths vary from 37m to 45m.

Character

Type B Major Arterials are characterized by a vibrant urban setting complete with animated building faces on both sides of the street, broad sidewalks, and street tree plantings suitable for high pedestrian and vehicular traffic. Double rows of street trees where space permits planted within continuous soil trenches and covered with large, walkable tree grates. Street furniture includes pedestrian lighting, cycle parking and seating opportunities allowing pedestrians to have an inviting place to linger.

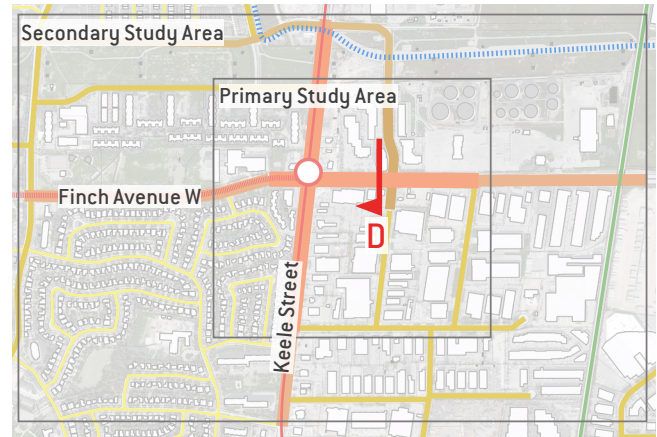

KEY PLAN

Features

Public Right-of-Way & Setback Features include:

- Please refer to preceding Major Arterial section as it applies here.

Median Features include:

- Medians less than 2.0m in width to be paved using City Standard rectangular unit paver in charcoal colour or approved alternative;
- Trees shall be planted in a single row along all medians that exceed 2.0m in width at a 6.0m spacing provided City of Toronto standard soil volumes are achieved;
- Irrigation shall be included for all planting areas.

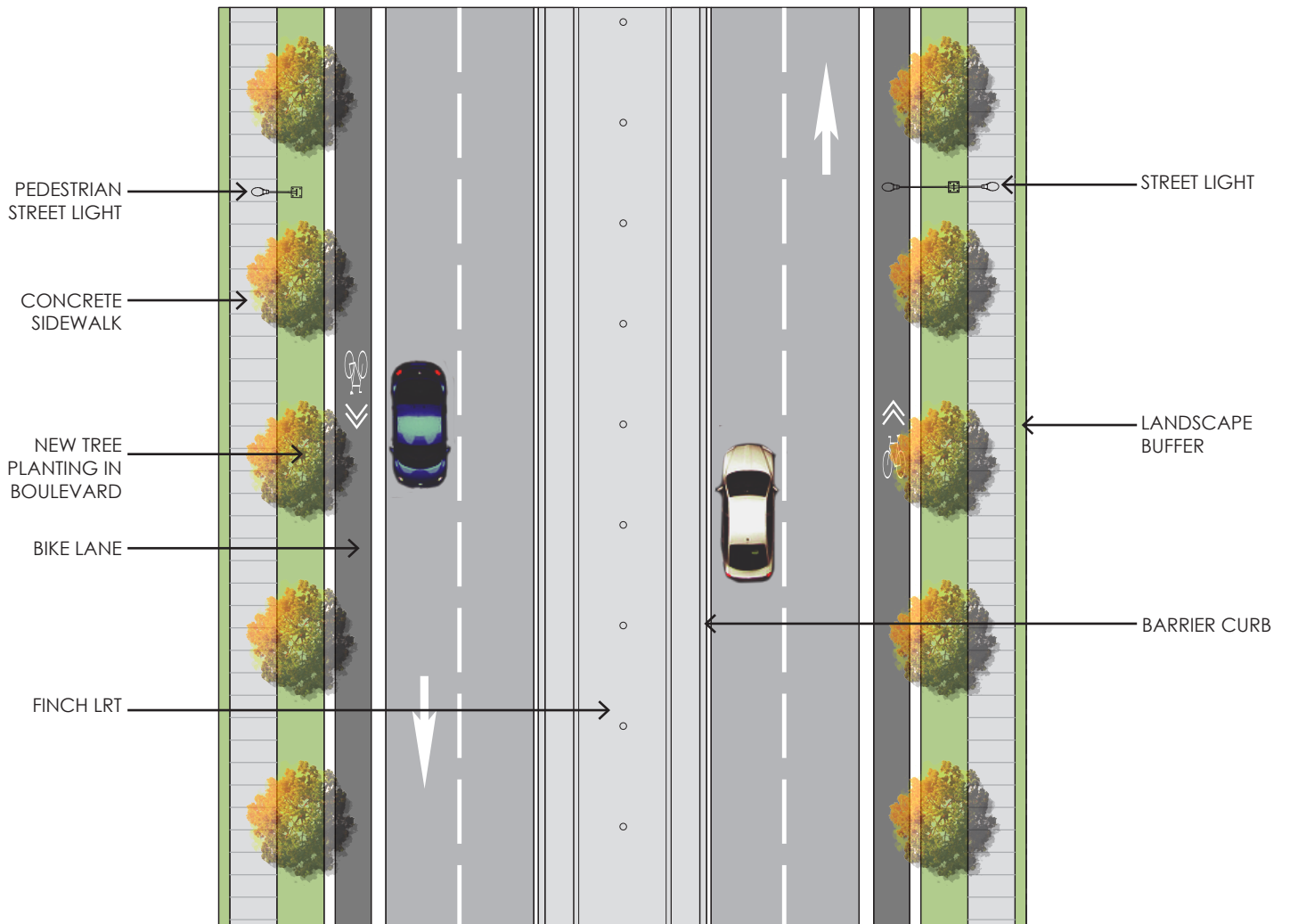
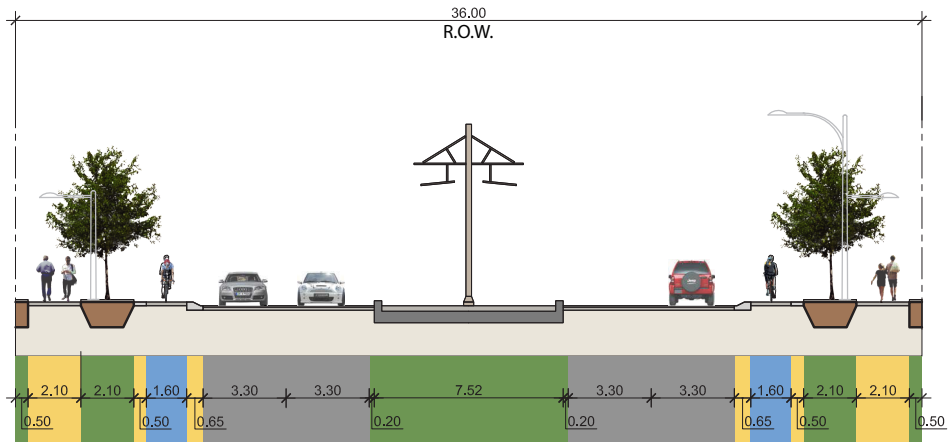

Arterial - midblock

Finch Avenue W - west of Keele Street

Description

The Arterial Typology applies to large thoroughfares with a central median and a large setback. This corresponds with the Secondary Study Area, specifically Finch Ave. West from the LRT portal west of Keele Street running westbound to Sentinel Road. Major Arterial right-of-way widths vary from 36m to 45m.

Character

The Arterial typology west of Romfield Lane transitions from an urban setting to a transit parkway characterized by separated at-grade LRT corridor flanked by two way traffic lanes, raised bicycle lanes and wide treed boulevards that fronts on Fountainhead Park to the north and fenced residential properties to the south. Street furniture located in furnishing zones at 25m-50m intervals.

Features

Public Right-of-Way Features include:

- 13.0m-21.0m Boulevard within the Public Right-of-Way;
- Bike lanes are at equal grade to the sidewalk, and separated from vehicular traffic by a .65m curb zone and separated from adjacent planting/furnishing zones with a .50m edge zone;
- Bike lanes at intersections where they are at-grade with vehicles shall be painted using current City of Toronto standards;

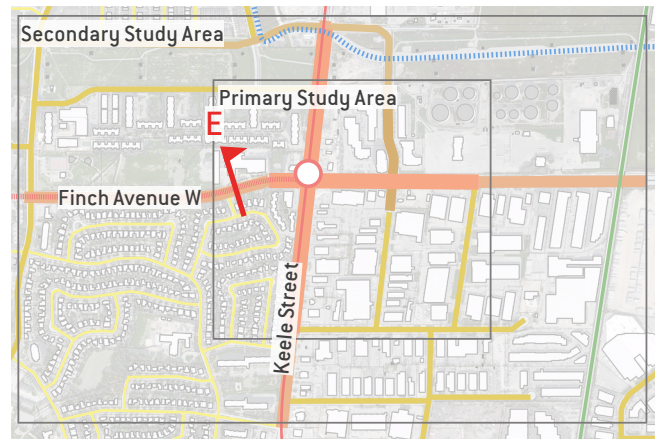

KEY PLAN

- 2.0m minimum furnishing zones shall be paved using City Standard rectangular unit paver in charcoal colour or approved alternative;
- Benches and litter recycling receptacles positioned facing into furnishing zone;
- Consolidate and coordinate street signage to reduce visual pollution;
- New trees to be planted within boulevard at a maximum 10.0m interval along both sides of the street where gaps are evident between existing trees;
- Species selection shall consist of a mix of native deciduous species with no single variety exceeding 25% of the total;
- Pedestrian light poles shall be provided at a maximum spacing of 15.0m;

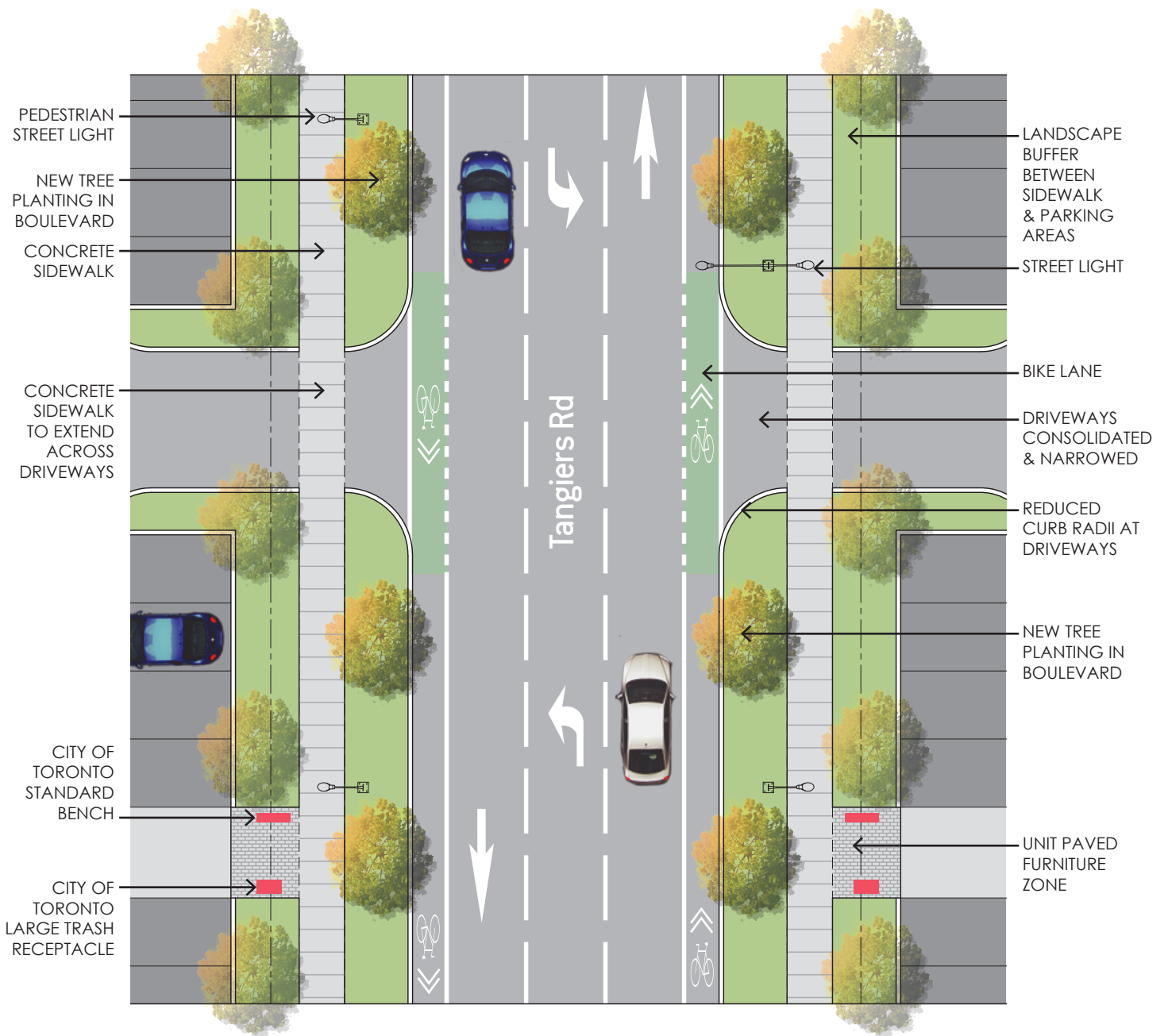
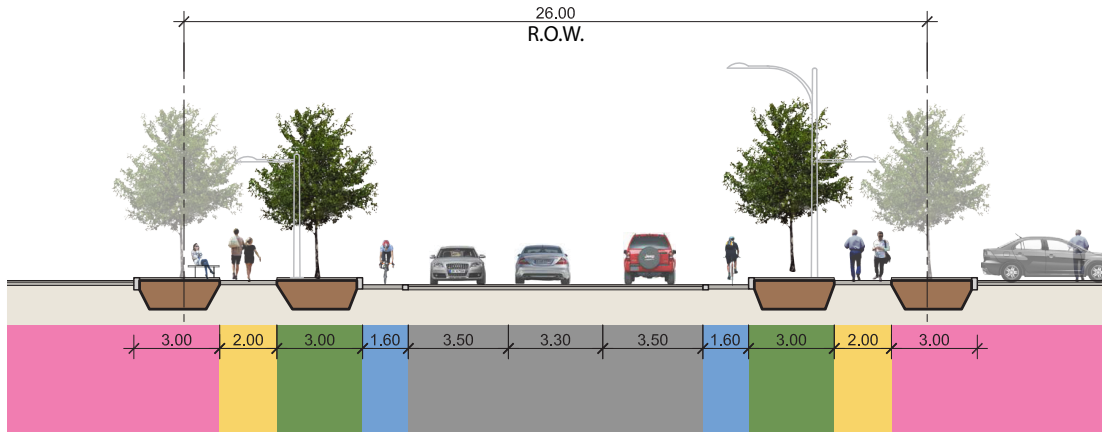

Major Collector Streets

Tangiers Rd. midblock north of Finch Ave W

Description

The Major Collector typology applies to secondary streets that balance large volumes of all user groups. This corresponds with Tangiers Rd in the vicinity of Finch Ave. West. Tangiers Rd. has a right-of-way width of 26m.

Character

Major Collectors are characterized by a walkable urban setting complete with safe connected pedestrian clearways on both sides of the street, and tree plantings suitable for high pedestrian and vehicular traffic. Double rows of street trees where space permits planted within large open planting areas. Street furniture located in furnishing zones at 25m-50m intervals.

Features

Public Right-of-Way Features include:

- 13.5m Boulevard within the Public Right-of-Way;
- Driveway entrances to be consolidated and narrowed to establish a safer more comfortable pedestrian environment;
- 1.6m bike lanes are at equal grade to the street, and painted using current City of Toronto standards at intersections and driveways;
- Furnishing zones shall be paved using City Standard rectangular unit paver in charcoal colour or approved alternative;
- 2.1m minimum concrete paved sidewalk with standard jointing;
- Tactile Walking Surface Indicators at all corners as per City Standards.
- Consolidate and coordinate street signage to reduce visual pollution;

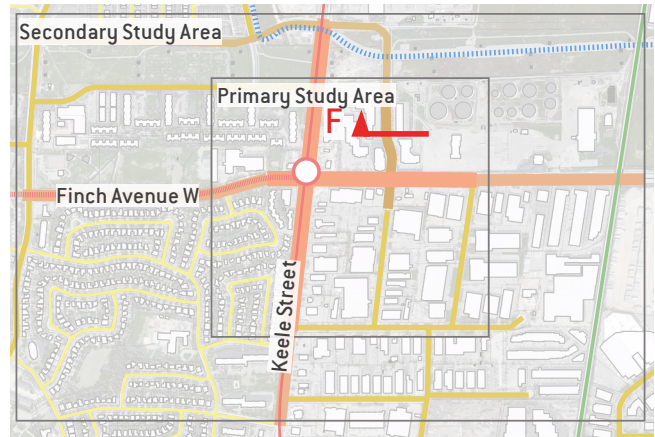

KEY PLAN

- Benches and litter recycling receptacles positioned facing into furnishing zone;
- Multi-publication structures/corrals at intersections;
- New trees to be planted within boulevard at a maximum 8.0m interval along both sides of the street;
- Species selection shall consist of a mix of native deciduous species with no single variety exceeding 25% of the total;
- Multi-purpose streetlight and pedestrian light poles shall be provided at a maximum spacing of 20.0m;
- Street light, hydro and signal poles shall include a minimum 2.5m anti-graffiti sleeve that includes DUKE Heights branding and colours.
- Bury hydro lines, to allow for a less cluttered streetscape.

Setback Features include:

- Where setbacks afford a flex zone, paving surface treatment must be seamless
- Where setback is greater than 2.0m, a second row of trees is encouraged.
- Flex Zone should be animated with cafes and/or other spill out commercial activity;

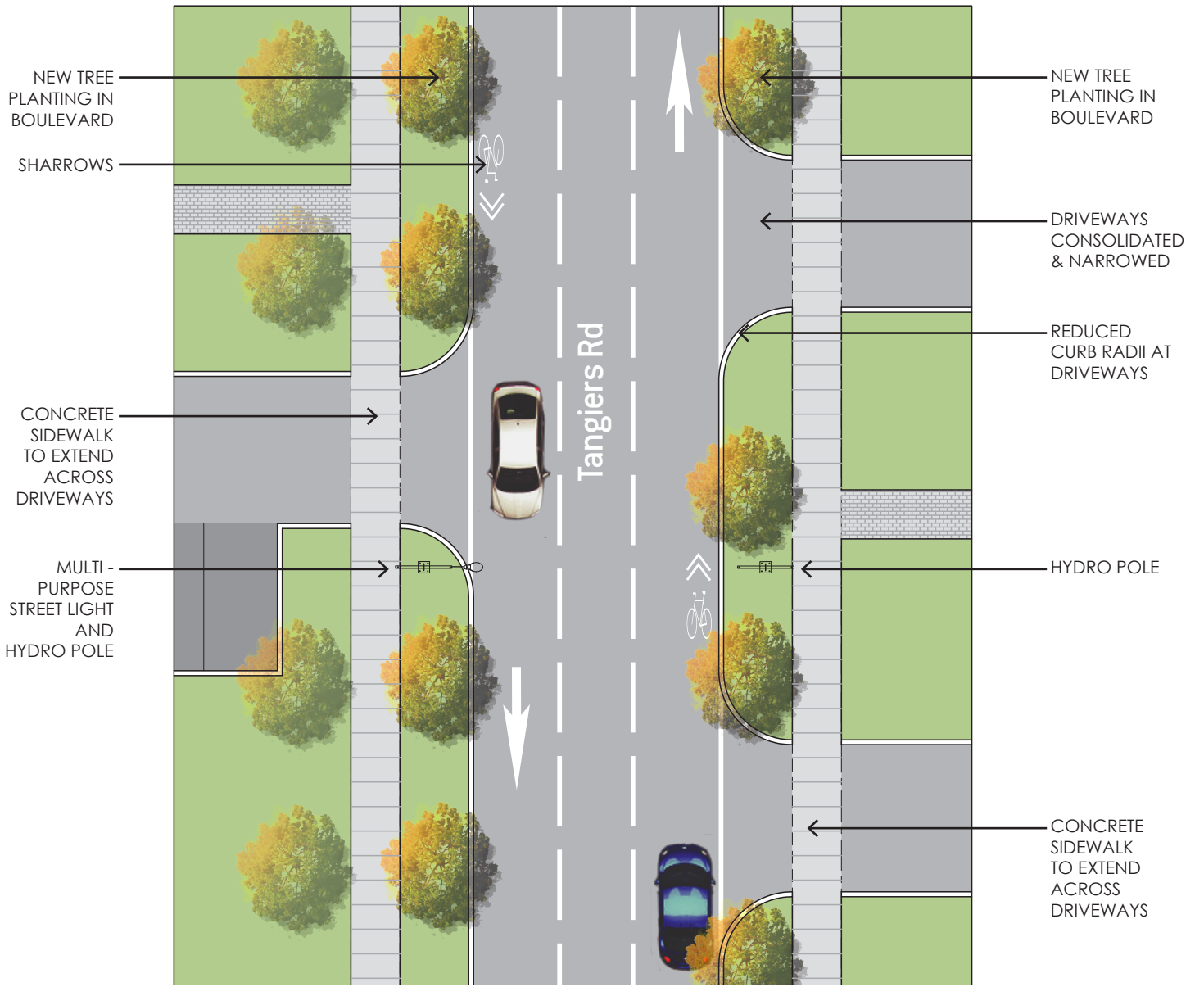
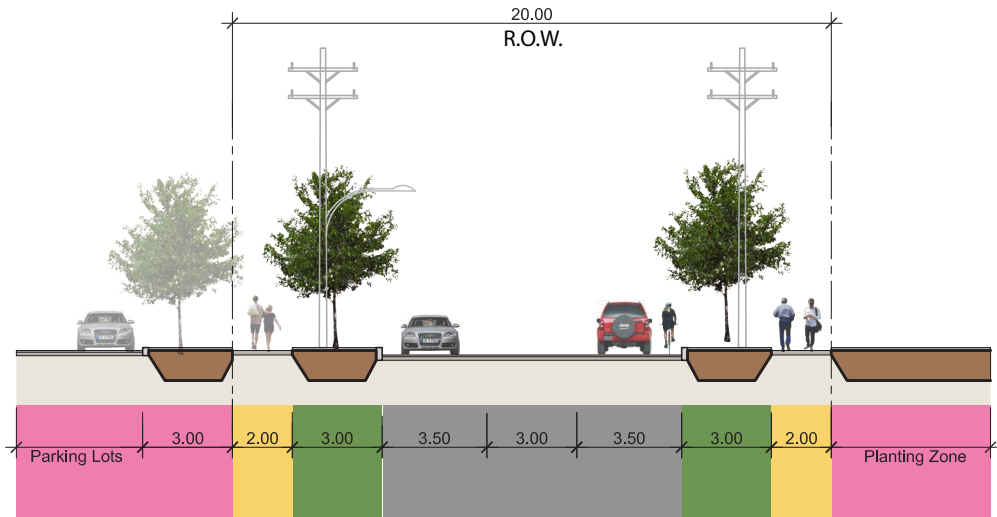

Collector Street 'A'

Tangiers Rd. midblock south of Finch Ave W

Description

The Collector 'A' Street typology applies to secondary streets with higher than average volumes of vehicle and pedestrian traffic. This corresponds with Tangiers Rd south of Finch Ave. W, and other employment area streets within a 20.0m right-of-way.

Character

Collector 'A' Streets are characterized by a narrow right-of-way street in employment areas with sidewalks setback from the curb edge with planted boulevards.

Features

Public Right-of-Way Features include:

- 10.0m Boulevard within the Public Right-of-Way;
- Driveway entrances to be consolidated and narrowed to establish a safer more comfortable pedestrian environment;
- Shared lane markings to be applied along length of Collector Streets for bicycle traffic, and painted using current City of Toronto standards at intersections;
- 2.0m minimum concrete paved sidewalk with standard jointing;
- Sidewalks to extend across driveways;
- Tactile Walking Surface Indicators at all corners as per City Standards.
- Consolidate and coordinate street signage to reduce visual pollution;
- New trees to be planted within boulevard at a maximum 10.0m interval along both sides of the street;

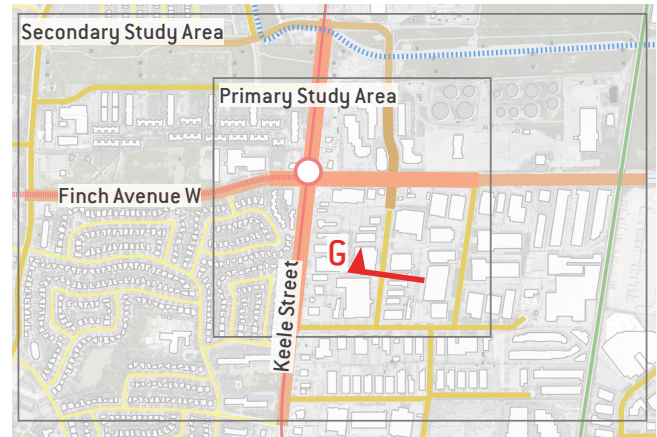

KEY PLAN

- Species selection shall consist of a mix of native deciduous species with no single variety exceeding 25% of the total;
- Multi-purpose streetlight and pedestrian light poles shall be provided at a maximum spacing of 20.0m;

Setback Features include:

- Landscape buffers to be separate sidewalk and private parking areas;
- Where space permits, a second row of trees is encouraged on private property.

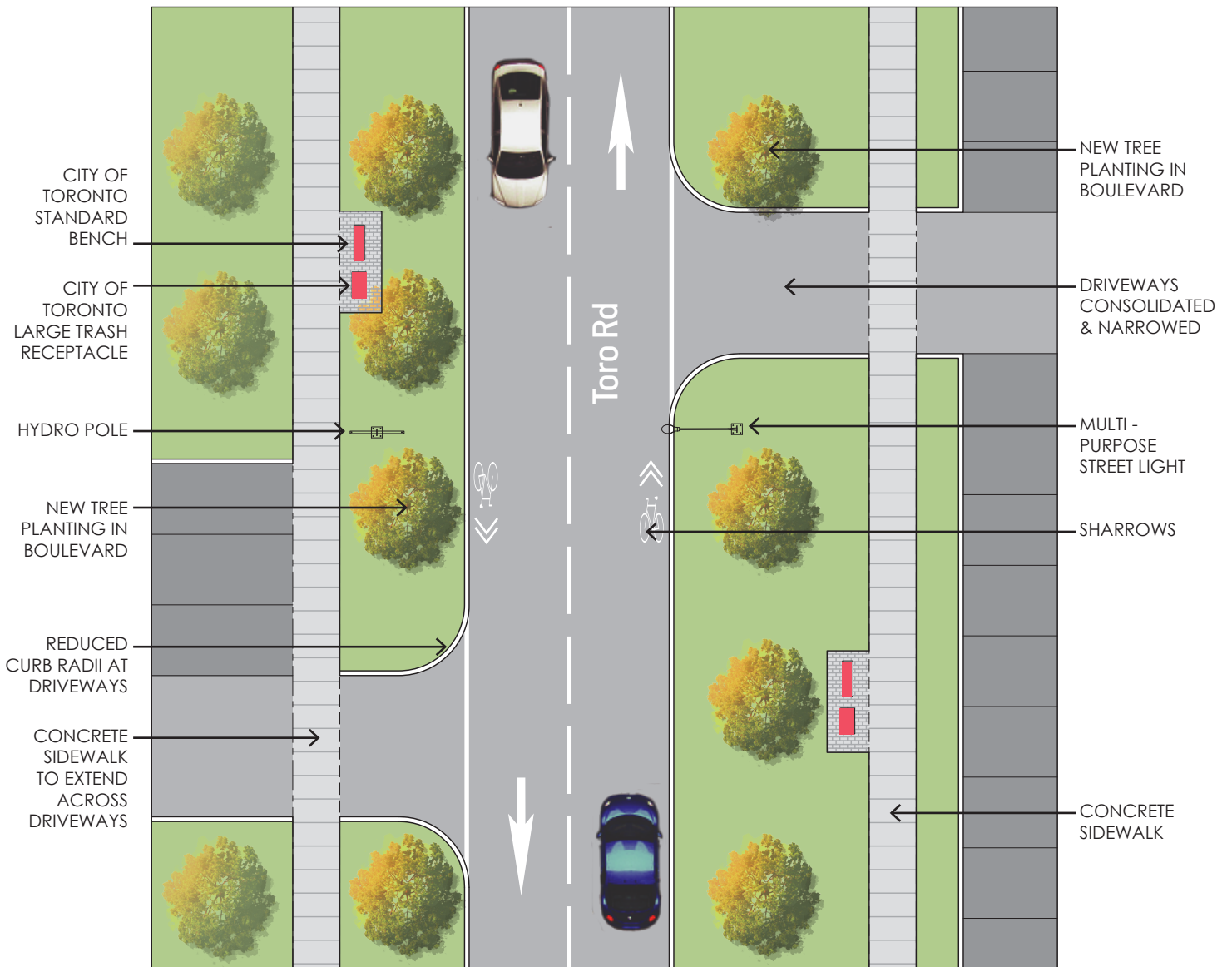
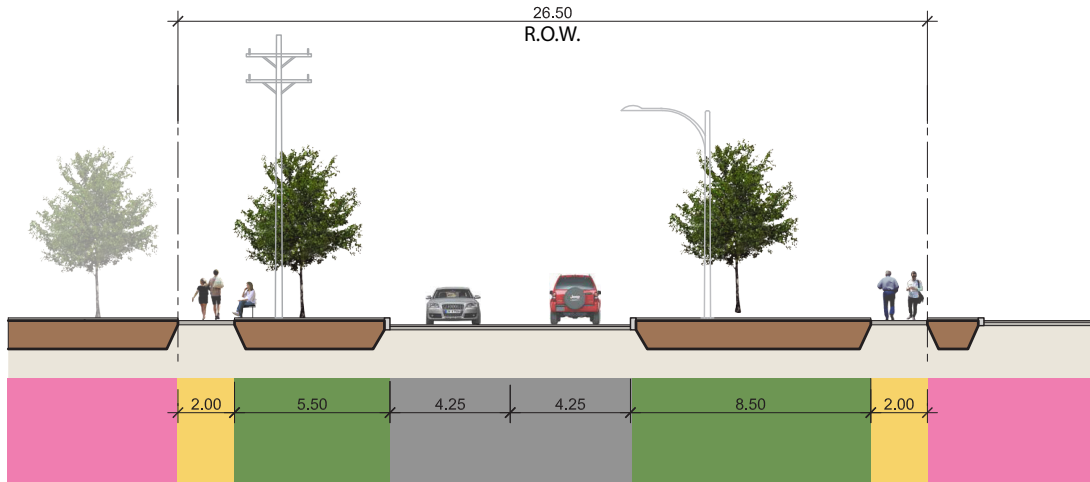

Collector Street B Toro Rd. midblock

Description

The Collector 'B' Street typology applies to secondary streets with higher than average volumes of vehicle and pedestrian traffic. This corresponds with Toro Rd., and other employment area streets within a 26.0m right-of-way.

Character

Collector 'B' Streets are characterized by a wide right-of-way street in employment areas with sidewalks with large setbacks from the curb edge with planted boulevards. Street furniture located in furnishing zones at 25m-50m intervals.

Features

Public Right-of-Way Features include:

- 8.5m Boulevard within the Public Right-of-Way;
- Driveway entrances to be consolidated and narrowed to establish a safer more comfortable pedestrian environment;
- Shared lane markings to be applied along length of Collector Streets for bicycle traffic, and painted using current City of Toronto standards at intersections;
- 2.0m minimum concrete paved sidewalk with standard jointing;
- Sidewalks to extend across driveways;
- Tactile Walking Surface Indicators at all corners as per City Standards.
- Furnishing zones shall be paved using City Standard rectangular unit paver in charcoal colour or approved alternative;
- Benches and litter recycling receptacles positioned facing into furnishing zone;
- Consolidate and coordinate street signage to reduce visual pollution;

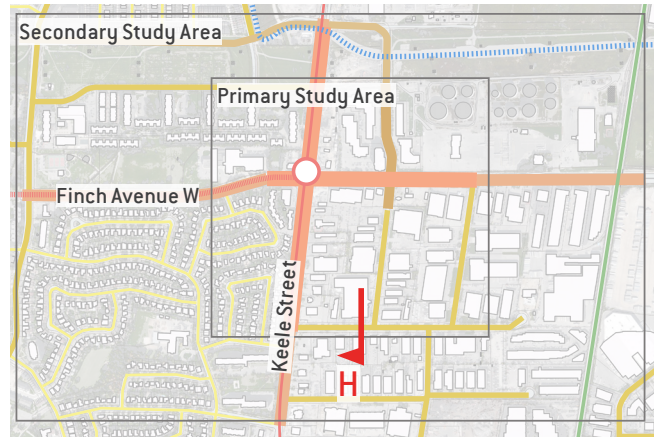

KEY PLAN

- New trees to be planted within boulevard at a maximum 10.0m interval along both sides of the street;
- Species selection shall consist of a mix of native deciduous species with no single variety exceeding 25% of the total;

Setback Features include:

- Landscape buffers to separate sidewalk and private parking areas;
- Where space permits, a second row of trees is encouraged on private property.

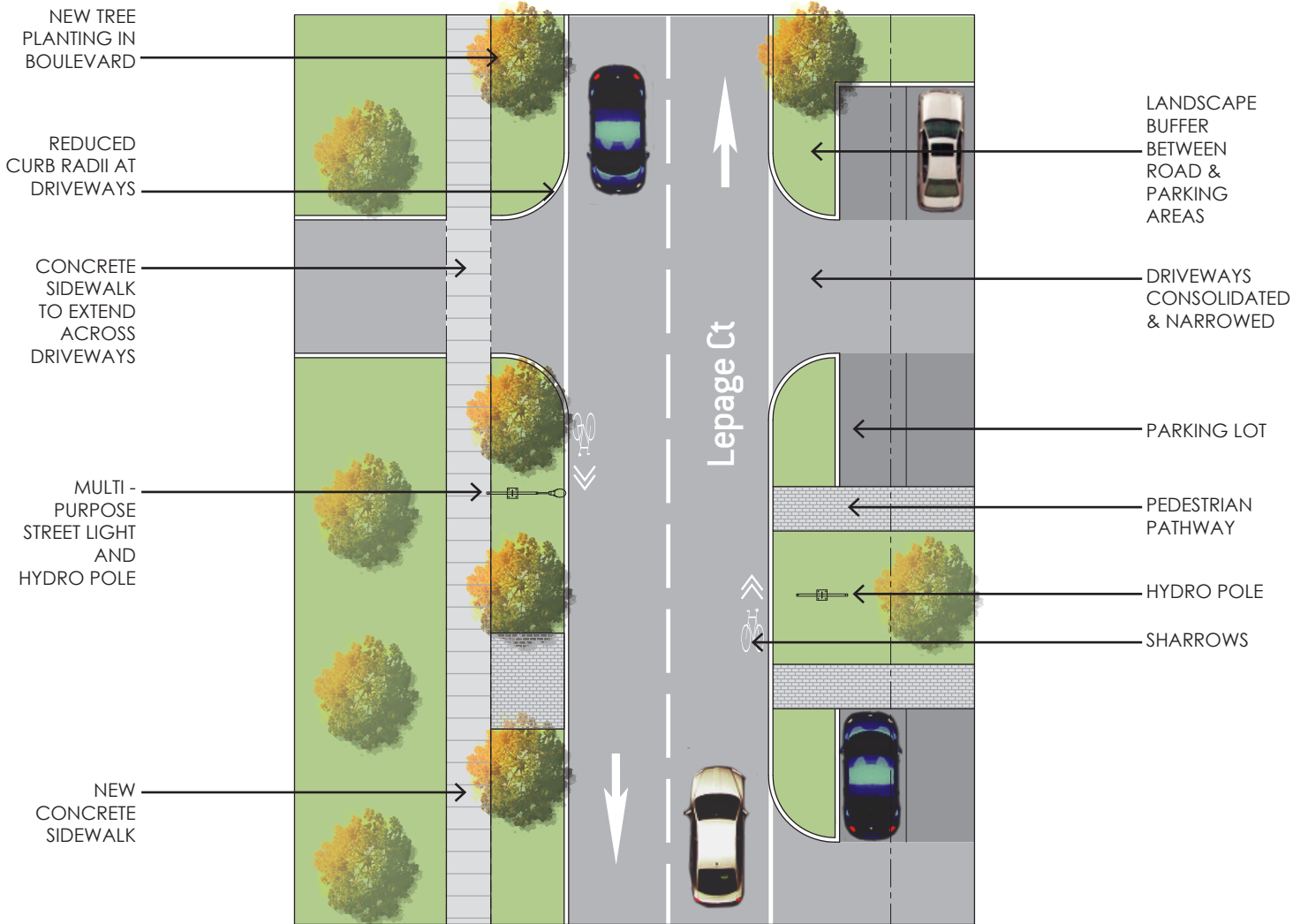
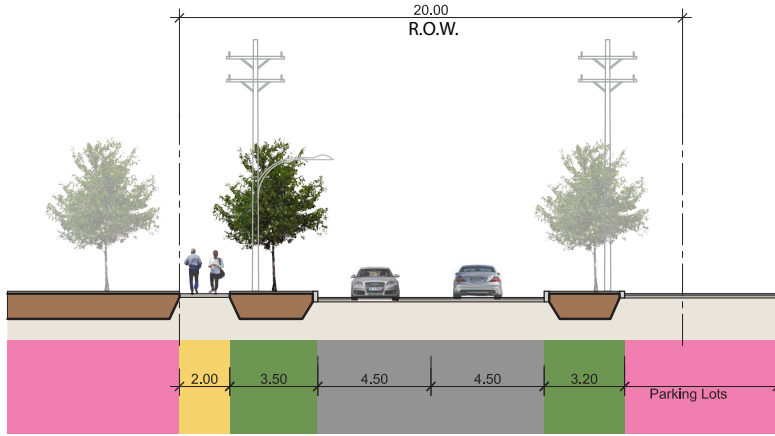

Local Street

Lepage Ct. midblock

Description

The Local Street typology applies to tertiary streets within employment areas with minor through-traffic and limited pedestrian traffic. This corresponds with Lepage Ct. and other tertiary employment area streets within a 20.0m right-of-way.

Character

Local Streets are characterized by narrow right-of-way streets in employment areas where surface parking predominates the front setback of buildings. A single sidewalk will flank the side of the street opposite existing hydro poles, and be complimented by a row of trees in a planted boulevard.

Features

Public Right-of-Way Features include:

- 9.0m Boulevard within the Public Right-of-Way;
- Driveway entrances to be consolidated and narrowed to establish a safer more comfortable pedestrian environment;
- Shared Lane Markings to be applied along length of Collector Streets for bicycle traffic, and painted using current City of Toronto standards at intersections;
- 2.0m minimum concrete paved sidewalk with standard jointing;
- Sidewalks to extend across driveways;
- Tactile Walking Surface Indicators at all corners as per City Standards.
- Consolidate and coordinate street signage to reduce visual pollution;
- New trees to be planted within boulevard at a maximum 10.0m interval along both sides of the street;

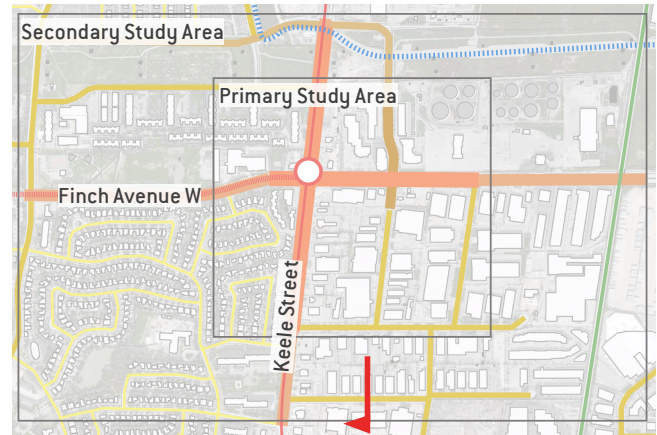

KEY PLAN

- Species selection shall consist of a mix of native deciduous species with no single variety exceeding 25% of the total;

Setback Features include:

- Landscape buffers to be separate sidewalk and private parking areas;
- Where space permits, a second row of trees is encouraged.

DRAFT

SIX// implementation

Preliminary Cost Estimate

The cost associated with designs presented in this document have been itemized by typology and estimated in the following pages.

Although not necessarily the responsibility of the BIA, all associated capital costs for the different streetscape improvements have been itemized for reference.

Duke Heights Preliminary Cost Estimate

07-Mar-16

Item	Description	Unit	Qty	Rate	Total
1.0 Finch Ave E. to Tanglers - 250m					
1.1	CIP Sidewalks incl. subgrade	m2	1600	\$ 120.00	\$ 192,000.00
1.2	Concrete Unit Paving (Furniture Zone)	m2	600	\$ 250.00	\$ 150,000.00
1.3	Concrete Unit Paving (Median Zone)	m2	1450	\$ 250.00	\$ 362,500.00
1.4	Bike Lane Infrastructure (Curb & Edge Zone)	m2	1375	\$ 90.00	\$ 123,750.00
1.5	Tactile Warning Indicator Plates	Each	4	\$ 1,000.00	\$ 4,000.00
1.6	Street Lighting	Each	8	\$ 10,000.00	\$ 80,000.00
1.7	Pedestrian Lighting	Each	16	\$ 8,000.00	\$ 128,000.00
1.8	Uplighting (Intersections)	Each	8	\$ 1,000.00	\$ 8,000.00
1.9	Bench	Each	8	\$ 1,500.00	\$ 12,000.00
1.10	Waste receptacle	Each	8	\$ 1,200.00	\$ 9,600.00
1.11	Bike ring	Each	20	\$ 1,000.00	\$ 20,000.00
1.12	News Corral	Each	2	\$ 2,000.00	\$ 4,000.00
1.13	Wayfinding	Each	2	\$ 1,500.00	\$ 3,000.00
1.14	Tree Grates	Each	12	\$ 1,500.00	\$ 18,000.00
1.15	Trees - 8m O.C.	Each	70	\$ 800.00	\$ 56,000.00
1.16	Understory Planting Zones	m2	1000	\$ 40.00	\$ 40,000.00
1.17	Planting Soil	m3	250	\$ 60.00	\$ 15,000.00
1.18	Soil Cells	Each	850	\$ 40.00	\$ 34,000.00
1.19	Planter Fence	Each	30	\$ 4,000.00	\$ 120,000.00
				Sub Total	\$ 1,379,850.00
2.0 Finch Ave E. - Tanglers to CP Rail - 600m					
2.1	CIP Sidewalks incl. subgrade	m2	2400	\$ 120.00	\$ 288,000.00
2.2	Concrete Unit Paving (Furniture Zone)	m2	300	\$ 250.00	\$ 75,000.00
2.3	Concrete Unit Paving (Median Zone)	m2	1000	\$ 250.00	\$ 250,000.00
2.4	Bike Lane Infrastructure (Curb & Edge Zone)	m2	3300	\$ 90.00	\$ 297,000.00
2.5	Tactile Warning Indicator Plates	Each	4	\$ 1,000.00	\$ 4,000.00
2.6	Street Lighting	Each	15	\$ 10,000.00	\$ 150,000.00
2.7	Pedestrian Lighting	Each	25	\$ 8,000.00	\$ 200,000.00
2.8	Uplighting (Intersections)	Each	8	\$ 1,000.00	\$ 8,000.00
2.9	Bench	Each	8	\$ 1,500.00	\$ 12,000.00
2.10	Waste receptacle	Each	4	\$ 1,200.00	\$ 4,800.00
2.11	Bike ring	Each	10	\$ 1,000.00	\$ 10,000.00
2.12	Tree Grates	Each	6	\$ 1,500.00	\$ 9,000.00
2.13	Trees - 8m O.C.	Each	100	\$ 800.00	\$ 80,000.00
2.14	Understory Planting Zones	m2	1200	\$ 40.00	\$ 48,000.00
2.15	Planting Soil	m3	150	\$ 60.00	\$ 9,000.00
2.16	Soil Cells	Each	420	\$ 40.00	\$ 16,800.00
2.17	Planter Fence	Each	40	\$ 2,000.00	\$ 80,000.00
				Sub Total	\$ 1,541,600.00

3.0 Finch Ave W. to Romsfield - 200m

3.1 CIP Sidewalks incl. subgrade	1500 \$	120.00 \$	180,000.00
3.2 Concrete Unit Paving (Furniture Zone)	600 \$	250.00 \$	150,000.00
3.3 Concrete Unit Paving (Median Zone)	1450 \$	250.00 \$	362,500.00
3.4 Bike Lane Infrastructure (Curb & Edge Zone)	1375 \$	90.00 \$	123,750.00
3.5 Tactile Warning Indicator Plates	2 \$	1,000.00 \$	2,000.00
3.6 Street Lighting	8 \$	10,000.00 \$	80,000.00
3.7 Pedestrian Lighting	16 \$	8,000.00 \$	128,000.00
3.8 Uplighting (Intersections)	8 \$	1,000.00 \$	8,000.00
3.9 Bench	8 \$	1,500.00 \$	12,000.00
3.10 Waste receptacle	8 \$	1,200.00 \$	9,600.00
3.11 Bike ring	20 \$	1,000.00 \$	20,000.00
3.12 News Corral	2 \$	2,000.00 \$	4,000.00
3.13 Wayfinding	2 \$	1,500.00 \$	3,000.00
3.14 Tree Grates	12 \$	1,500.00 \$	18,000.00
3.15 Trees - 8m O.C.	70 \$	800.00 \$	56,000.00
3.16 Understorey Planting Zones	1000 \$	40.00 \$	40,000.00
3.17 Planting Soil	250 \$	60.00 \$	15,000.00
3.18 Soil Cells	850 \$	40.00 \$	34,000.00
3.19 Planter Fence	30 \$	4,000.00 \$	120,000.00
		Sub Total	1,365,850.00

4.0 Finch Ave W. Romsfield to Sentinel - 550m

4.1 Concrete Unit Paving (Furniture Zone)	200 \$	250.00 \$	50,000.00
4.2 Bike Lane Infrastructure (Curb & Edge Zone)	3025 \$	90.00 \$	272,250.00
4.3 Tactile Warning Indicator Plates	4 \$	1,000.00 \$	4,000.00
4.4 Pedestrian Lighting	30 \$	8,000.00 \$	240,000.00
4.5 Trees - 8m O.C.	25 \$	800.00 \$	20,000.00
		Sub Total	586,250.00

5.0 Keele Ave. Finch to Murray Ross - 400m

5.1 CIP Sidewalks incl. subgrade	1600 \$	120.00 \$	192,000.00
5.2 Concrete Unit Paving (Furniture Zone)	500 \$	250.00 \$	125,000.00
5.3 Concrete Unit Paving (Median Zone)	400 \$	250.00 \$	100,000.00
5.4 Bike Lane Infrastructure (Curb & Edge Zone)	2200 \$	90.00 \$	198,000.00
5.5 Tactile Warning Indicator Plates	6 \$	1,000.00 \$	6,000.00
5.6 Street Lighting	22 \$	10,000.00 \$	220,000.00
5.7 Pedestrian Lighting	40 \$	8,000.00 \$	320,000.00
5.8 Uplighting (Intersections)	8 \$	1,000.00 \$	8,000.00
5.9 Bench	12 \$	1,500.00 \$	18,000.00
5.10 Waste receptacle	8 \$	1,200.00 \$	9,600.00
5.11 Bike ring	10 \$	1,000.00 \$	10,000.00
5.12 News Corral	2 \$	2,000.00 \$	4,000.00
5.13 Wayfinding	2 \$	1,500.00 \$	3,000.00
5.14 Tree Grates	6 \$	1,500.00 \$	9,000.00
5.15 Trees - 8m O.C.	120 \$	800.00 \$	96,000.00
5.16 Understorey Planting Zones	1500 \$	40.00 \$	60,000.00
5.17 Planting Soil	150 \$	60.00 \$	9,000.00
5.18 Soil Cells	400 \$	40.00 \$	16,000.00
5.19 Planter Fence	20 \$	4,000.00 \$	80,000.00
		Sub Total	1,483,600.00

Duke Heights Preliminary Cost Estimate

07-Mar-16

Item	Description	Unit	Qty	Rate	Total
6.0 Keele Ave. Finch to Toro - 400m					
6.1	CIP Sidewalks incl. subgrade	m2	1600	\$ 120.00	\$ 192,000.00
6.2	Concrete Unit Paving (Furniture Zone)	m2	500	\$ 250.00	\$ 125,000.00
6.3	Concrete Unit Paving (Median Zone)	m2	400	\$ 250.00	\$ 100,000.00
6.4	Bike Lane Infrastructure (Curb & Edge Zone)	m2	2200	\$ 90.00	\$ 198,000.00
6.5	Tactile Warning Indicator Plates	Each	6	\$ 1,000.00	\$ 6,000.00
6.6	Street Lighting	Each	22	\$ 10,000.00	\$ 220,000.00
6.7	Pedestrian Lighting	Each	40	\$ 8,000.00	\$ 320,000.00
6.8	Uplighting (Intersections)	Each	8	\$ 1,000.00	\$ 8,000.00
6.9	Bench	Each	12	\$ 1,500.00	\$ 18,000.00
6.10	Waste receptacle	Each	8	\$ 1,200.00	\$ 9,600.00
6.11	Bike ring	Each	10	\$ 1,000.00	\$ 10,000.00
6.12	News Corral	Each	2	\$ 2,000.00	\$ 4,000.00
6.13	Wayfinding	Each	2	\$ 1,500.00	\$ 3,000.00
6.14	Tree Grates	Each	6	\$ 1,500.00	\$ 9,000.00
6.15	Trees - 8m O.C.	Each	120	\$ 800.00	\$ 96,000.00
6.16	Understory Planting Zones	m2	1500	\$ 40.00	\$ 60,000.00
6.17	Planting Soil	m3	150	\$ 60.00	\$ 9,000.00
6.18	Soil Cells	Each	400	\$ 40.00	\$ 16,000.00
6.19	Planter Fence	Each	20	\$ 4,000.00	\$ 80,000.00
				Sub Total	\$ 1,483,600.00
7.0 Keele Ave. Toro to Lepage - 250m					
7.1	CIP Sidewalks incl. subgrade	m2	1000	\$ 120.00	\$ 120,000.00
7.2	Bike Lane Infrastructure (Curb & Edge Zone)	m2	1375	\$ 90.00	\$ 123,750.00
7.3	Tactile Warning Indicator Plates	Each	2	\$ 1,000.00	\$ 2,000.00
7.4	Pedestrian Lighting	Each	8	\$ 8,000.00	\$ 64,000.00
7.5	Trees - 8m O.C.	Each	50	\$ 800.00	\$ 40,000.00
				Sub Total	\$ 349,750.00
8.0 Tanglers - Finch to Keele - 550m					
8.1	Concrete Unit Paving (Furniture Zone)	m2	150	\$ 250.00	\$ 37,500.00
8.2	Bench	Each	6	\$ 1,500.00	\$ 9,000.00
8.3	Waste receptacle	Each	4	\$ 1,200.00	\$ 4,800.00
8.4	Trees - 8m O.C.	Each	50	\$ 800.00	\$ 40,000.00
				Sub Total	\$ 91,300.00
9.0 Tanglers - Finch to Toro - 400m					
9.1	Waste receptacle	Each	4	\$ 1,200.00	\$ 4,800.00
9.2	Trees - 8m O.C.	Each	40	\$ 800.00	\$ 32,000.00
				Sub Total	\$ 36,800.00

10.0 Murray Ross - Keele to Sentinel - 750m

10.1 Concrete Unit Paving (Furniture Zone)	400 \$	250.00 \$	100,000.00
10.2 Bench	12 \$	1,500.00 \$	18,000.00
10.3 Waste receptacle	5 \$	1,200.00 \$	6,000.00
10.4 Trees - 8m O.C.	140 \$	800.00 \$	112,000.00
		Sub Total	236,000.00

11.0 Four Winds - Keele to Sentinel - 750m

11.1 Concrete Unit Paving (Furniture Zone)	400 \$	250.00 \$	100,000.00
11.2 Bench	12 \$	1,500.00 \$	18,000.00
11.3 Waste receptacle	5 \$	1,200.00 \$	6,000.00
11.4 Trees - 8m O.C.	140 \$	800.00 \$	112,000.00
		Sub Total	236,000.00

12.0 Sentinel - 400m

12.1 Bench	8 \$	1,500.00 \$	12,000.00
12.2 Waste receptacle	4 \$	1,200.00 \$	4,800.00
12.3 Trees - 8m O.C.	100 \$	800.00 \$	80,000.00
		Sub Total	96,800.00

13.0 Toro - 600m

13.1 Concrete Unit Paving (Furniture Zone)	250 \$	250.00 \$	62,500.00
13.2 Bench	12 \$	1,500.00 \$	18,000.00
13.3 Waste receptacle	5 \$	1,200.00 \$	6,000.00
13.4 Trees - 8m O.C.	60 \$	800.00 \$	48,000.00
		Sub Total	134,500.00

14.0 Alexdon - 400m

14.1 Trees - 8m O.C.	50 \$	800.00 \$	40,000.00
		Sub Total	40,000.00

15.0 Lepage - 650m

15.1 CIP Sidewalks incl. subgrade	1300 \$	120.00 \$	156,000.00
15.2 Tactile Warning Indicator Plates	4 \$	1,000.00 \$	4,000.00
15.3 Trees - 8m O.C.	80 \$	800.00 \$	64,000.00
		Sub Total	224,000.00

16.0 Ceramic - 150m

16.1 Trees - 8m O.C.	10 \$	800.00 \$	8,000.00
		Sub Total	8,000.00

SUB TOTAL	\$	\$	9,293,900.00
DESIGN CONTINGENCY FEE (15%)	\$	\$	1,394,085.00
TOTAL	\$	\$	10,687,985.00

DRAFT

SEVEN // appendix

The following section is an index of all selected streetscape elements.

Elements include:

1. Litter & Recycling Receptacle - City of Toronto standard
2. Bench - City of Toronto standard
3. Bench - backless - City of Toronto standard
4. Multi-Publication Structure - City of Toronto standard
5. Multi Publication Corral - City of Toronto standard
6. Bicycle Ring - City of Toronto standard
7. Public Message Centre - City of Toronto standard
8. Toronto 360 Wayfinding Strategy
9. Street Light - - City of Toronto standard with pedestrian fixture
10. Typical Banner Installation - City of Toronto standard
11. Sidewalk uplight - City of Toronto standard
12. Pole wrap
13. Tree grate - City of Toronto standard
14. Tree fence - City of Toronto standard
15. Unit paving - City of Toronto standard
16. Concrete sidewalk - custom jointing
17. Urban Design Streetscape Manual - Guide to Standard Planting Options - City of Toronto standard

DRAFT

Format: W (720x117) Client :	No. Projet : Project No. :	YRT ref # :	Project Title : WRMT-Astral	Drawing Title : COVER PAGE & DRAWING LIST	Matériel :	Unités : inches Unité : [mm]	Tolérances Générales : General Tolerancing : Utiliser ces tolérances sauf indications contraires. Indicateurs de tolérances autres que ceux indiqués doivent être utilisés otherwise indicated. X.X = +1/32" X.X = +0.5mm X.X = -0.031" X.X = -0.05mm X.XX = ±0.015" X.XX = ±0.05mm X.XXX = ±0.007"	Notes (s) Générales(s): General Note(s):	Chargé de projet : Project Manager : Dessiné par : Drawn by : W. Lagacé	Numéro de dessin : Drawing Number : WRMT-A001 R2-1	Date : 13 Jan 2015 REV : -	
---------------------------------	-------------------------------	-------------	--------------------------------	---	------------	---------------------------------	--	---	--	--	-------------------------------------	--

No. ARTICLE	NUMERO DE PIECE	DESCRIPTION	QTE
1	WRM-P002	Protecteur pour porte	1
2	WRMT-L01(BODY)	Poubelle	3
3	WRM-A101	Assemblage plancher	1
4	WRM-A201	Assemblage Chassis	1
5	WRM-A301	Assemblage partie gauche	1
6	WRM-A401	Assemblage porte droite	1
7	WRM-I000	Assemblage jupe	1

PAINT OPTION #1 POWDER COAT + CLEAR HERBE VERT ZS511G283 GRIS CREPUSCULAIRE ZS611A250 ORANGE ZS611A251 CLEAR PZ512C12	PAINT OPTION #2 POWDER COAT + CLEAR BLACK US511N6 ORANGE ZS611A251 CLEAR PZ512C12
---	---

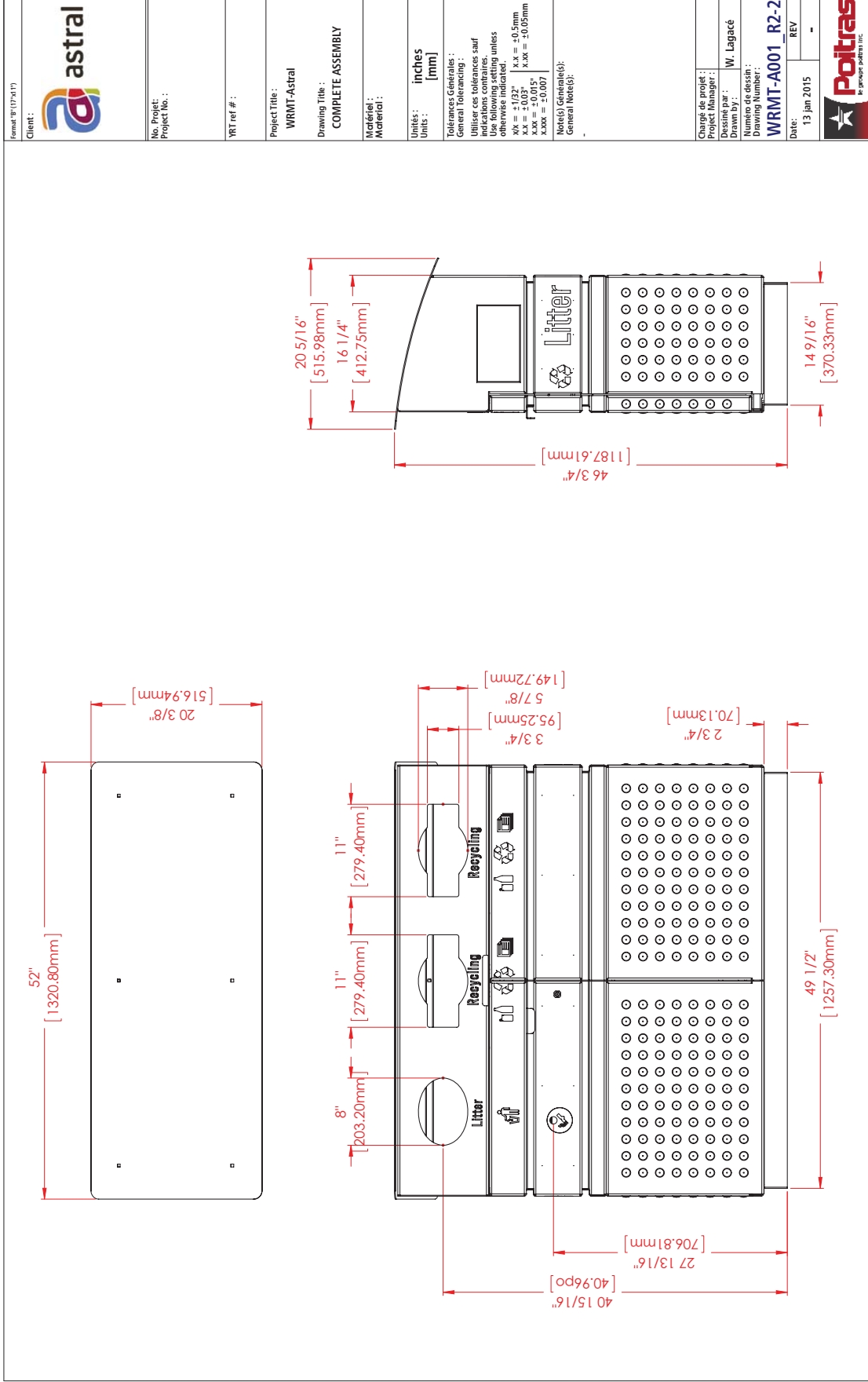

• FURNITURE •

BENCH AS SUPPLIED BY
TRANSWORLD SIGNS: 514-352-8030

BENCH IS NORMALLY INSTALLED FACING THE PEDESTRIAN CLEARWAY, EXCEPT AT TRANSIT STOPS WHERE IT IS INSTALLED FACING THE STREET (ALWAYS SECURE MINIMUM CLEARANCES FOR BARRIER-FREE ACCESS TO SEATING AREA)

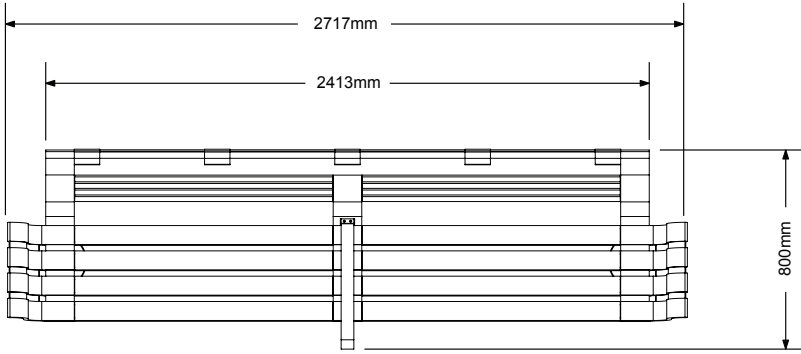

PLAN VIEW

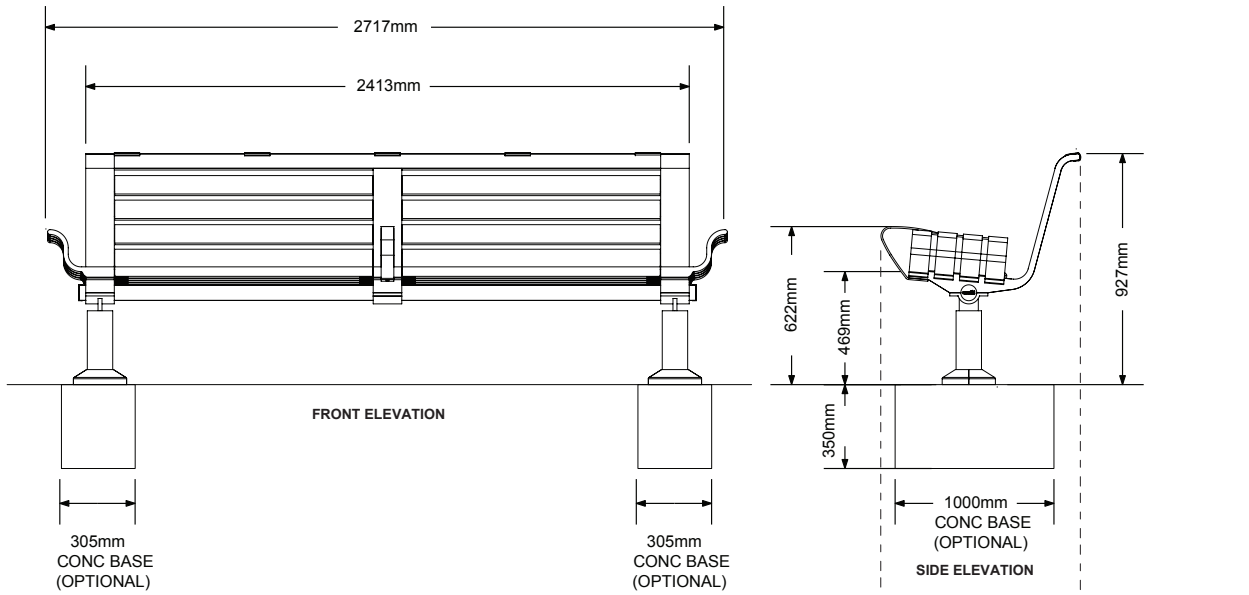

NOTE: OPTIONAL POURED IN PLACE CONCRETE BASE 25MPA. TROWEL FINISH EXPOSED SURFACE TO ENSURE THAT IT IS SMOOTH AND LEVEL

460mm MINIMUM SETBACK FROM SIDEWALK MAINTAIN PEDESTRIAN CLEARWAY (2100mm MINIMUM PREFERRED, 1700mm MINIMUM)

460mm MINIMUM CURB EDGE ZONE or SETBACK FROM SIDEWALK AT TRANSIT STOP LOCATION. MAINTAIN PEDESTRIAN CLEARWAY (2100mm MINIMUM PREFERRED, 1700mm MINIMUM)

<p>Toronto Urban Design Streetscape Manual</p>	<p>Bench With Four Seats Coordinated Street Furniture</p>	 <p>TORONTO F-1-3a NTS 05/10</p>
--	---	--

• FURNITURE •

BENCH AS SUPPLIED BY
TRANSWORLD SIGNS: 514-352-8030

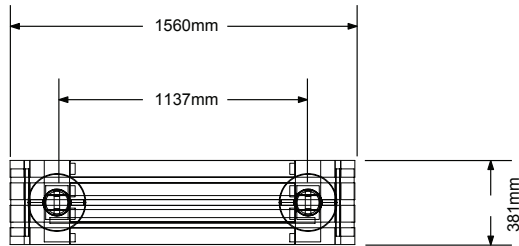

PLAN VIEW

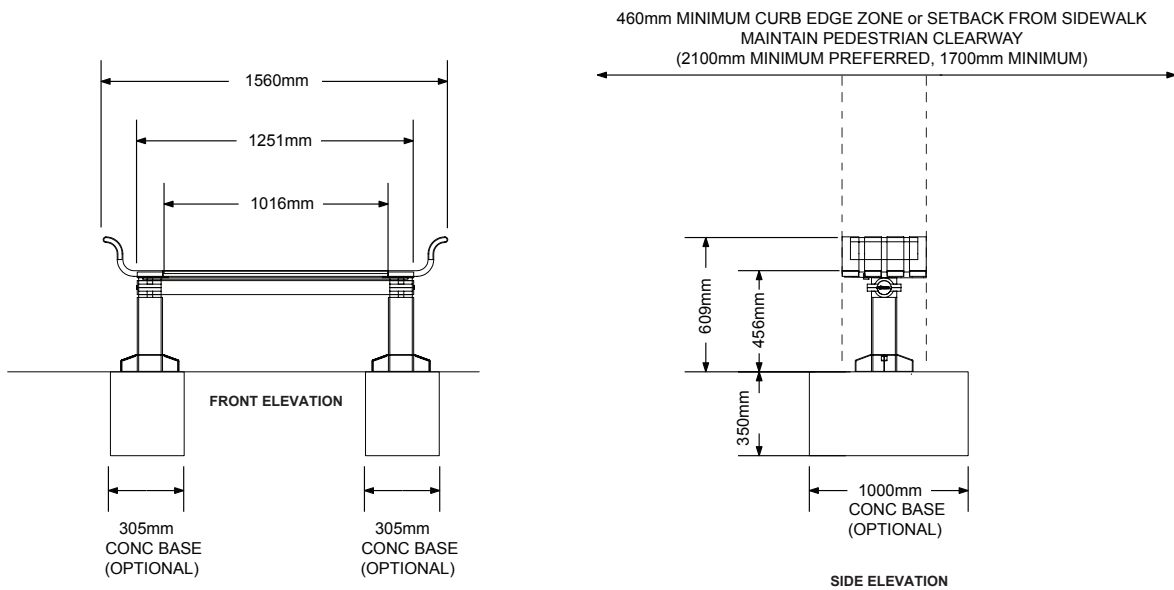

NOTE: OPTIONAL POURED IN PLACE
CONCRETE BASE 25MPA. TROWEL FINISH
EXPOSED SURFACE TO ENSURE THAT IT
IS SMOOTH AND LEVEL

<p>Toronto Urban Design Streetscape Manual</p>	<p>Bench With Two Seats Coordinated Street Furniture</p>	<p>TORONTO F-1-3b NTS 05/10</p>
--	--	---

• FURNITURE •

MULTI PUBLICATION STRUCTURE AS SUPPLIED
BY ENSEICOM: 1-800-663-0613

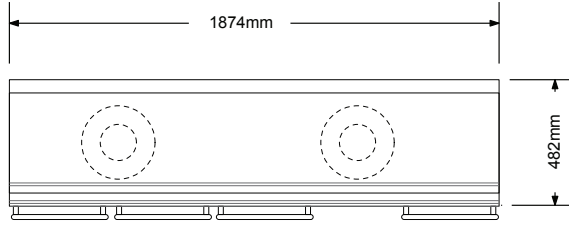

PLAN VIEW

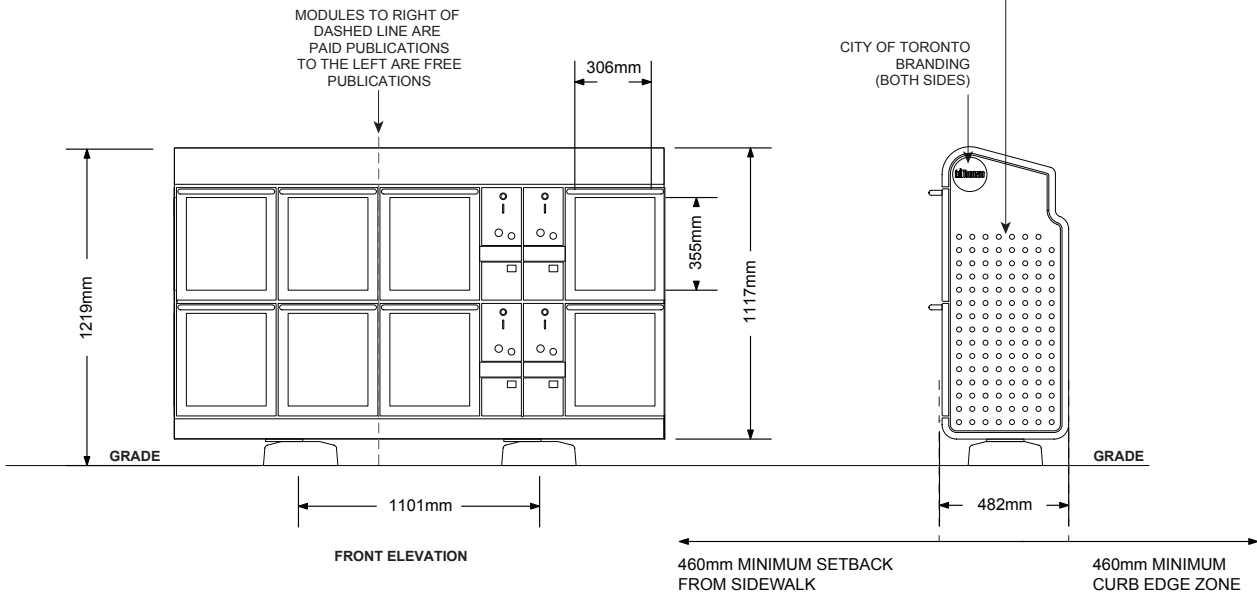

FRONT ELEVATION

SIDE ELEVATION

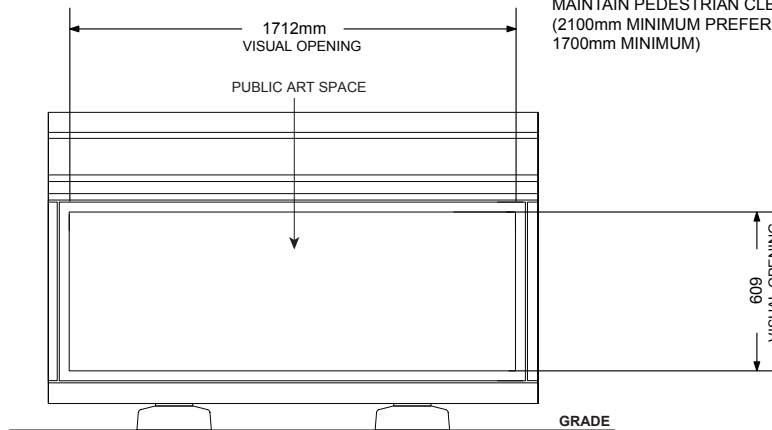

REAR ELEVATION

<p>Toronto Urban Design Streetscape Manual</p>	<p>Multi-Publication Structure (8 UNITS) Coordinated Street Furniture</p>	 <p>TORONTO F-1-4a NTS 05/10</p>
--	---	--

• FURNITURE •

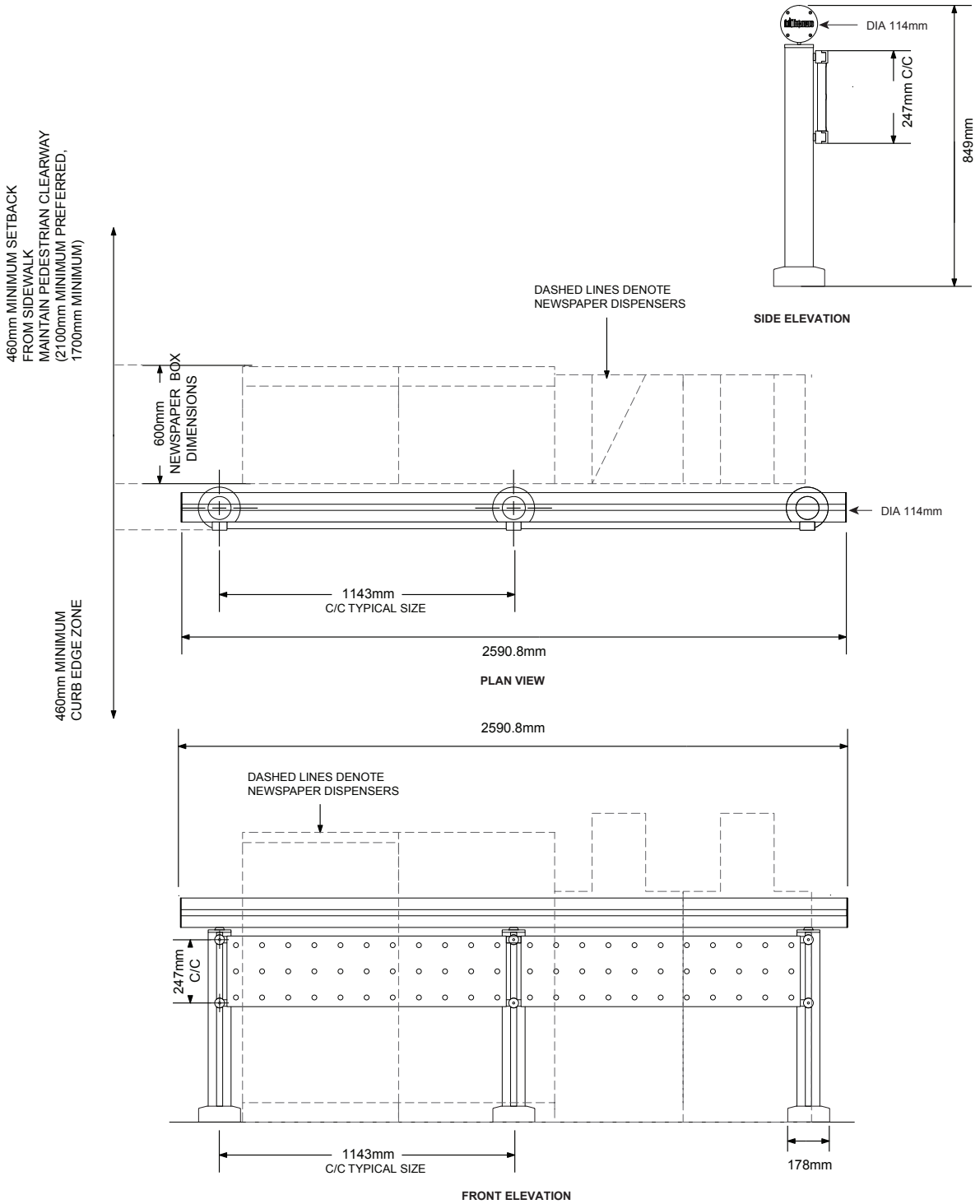

NOTE: SYSTEM CAN BE INCREASED TO A MAXIMUM OF 8 PUBLICATION BOXES

<p>Toronto Urban Design</p> <p>Streetscape Manual</p>	<p>Multi - Publication Box Corral (4 Box Modular Unit)</p> <p>Coordinated Street Furniture</p>	 <p>TORONTO</p> <p>F-1-5</p> <p>NTS 05/10</p>
---	--	---

• FURNITURE •

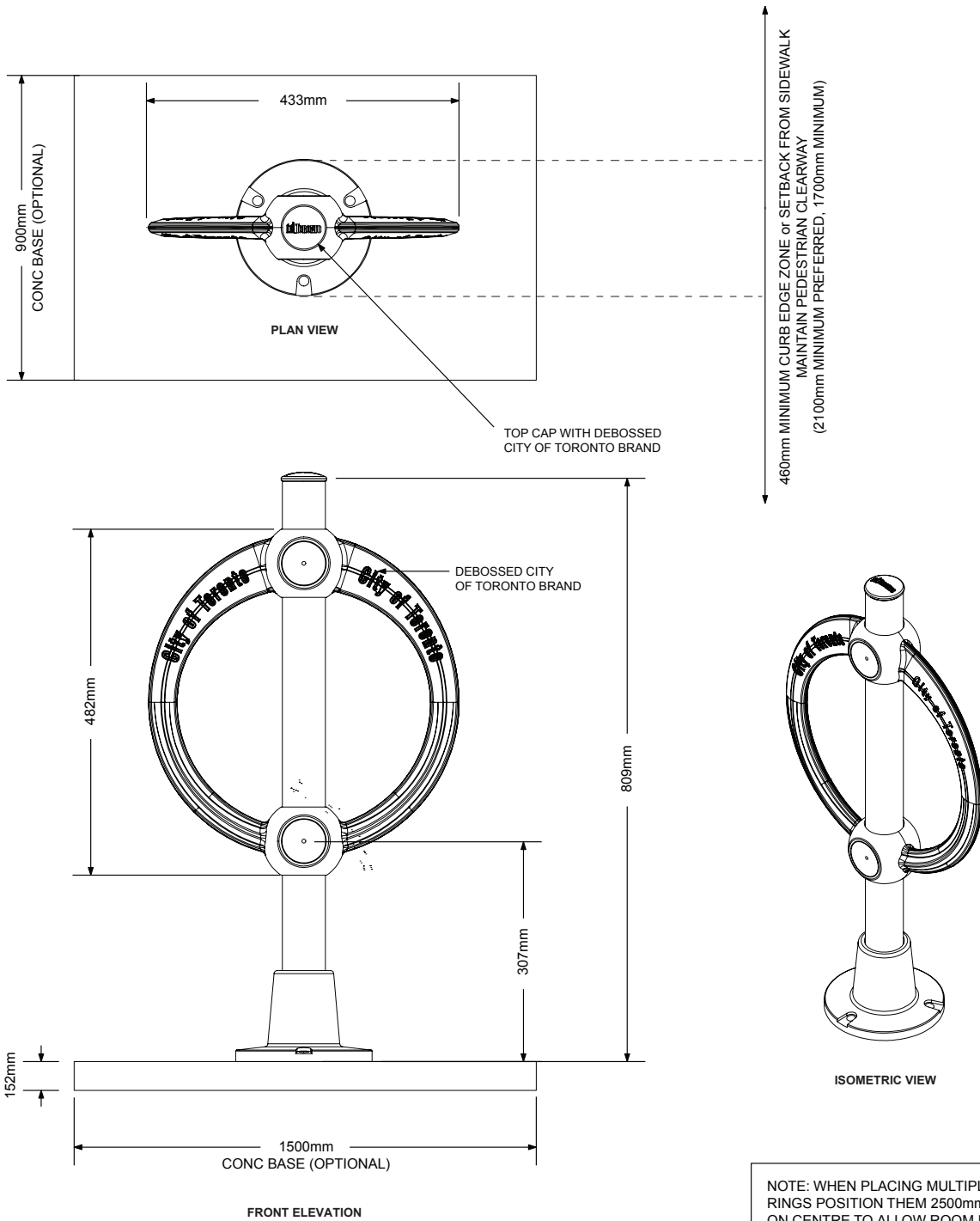

<p>Toronto Urban Design</p> <p>Streetscape Manual</p>	<p>Bicycle Ring</p> <p>Coordinated Street Furniture</p>	 <p>TORONTO</p> <p>F-1-6</p> <p>NTS 05/10</p>
---	---	--

• FURNITURE •

PUBLIC MESSAGE CENTRE AS SUPPLIED BY
ATEC SIGNS: 905-451-9720

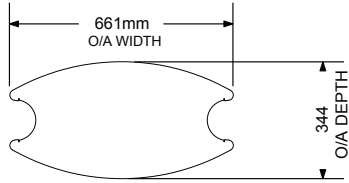

PLAN VIEW

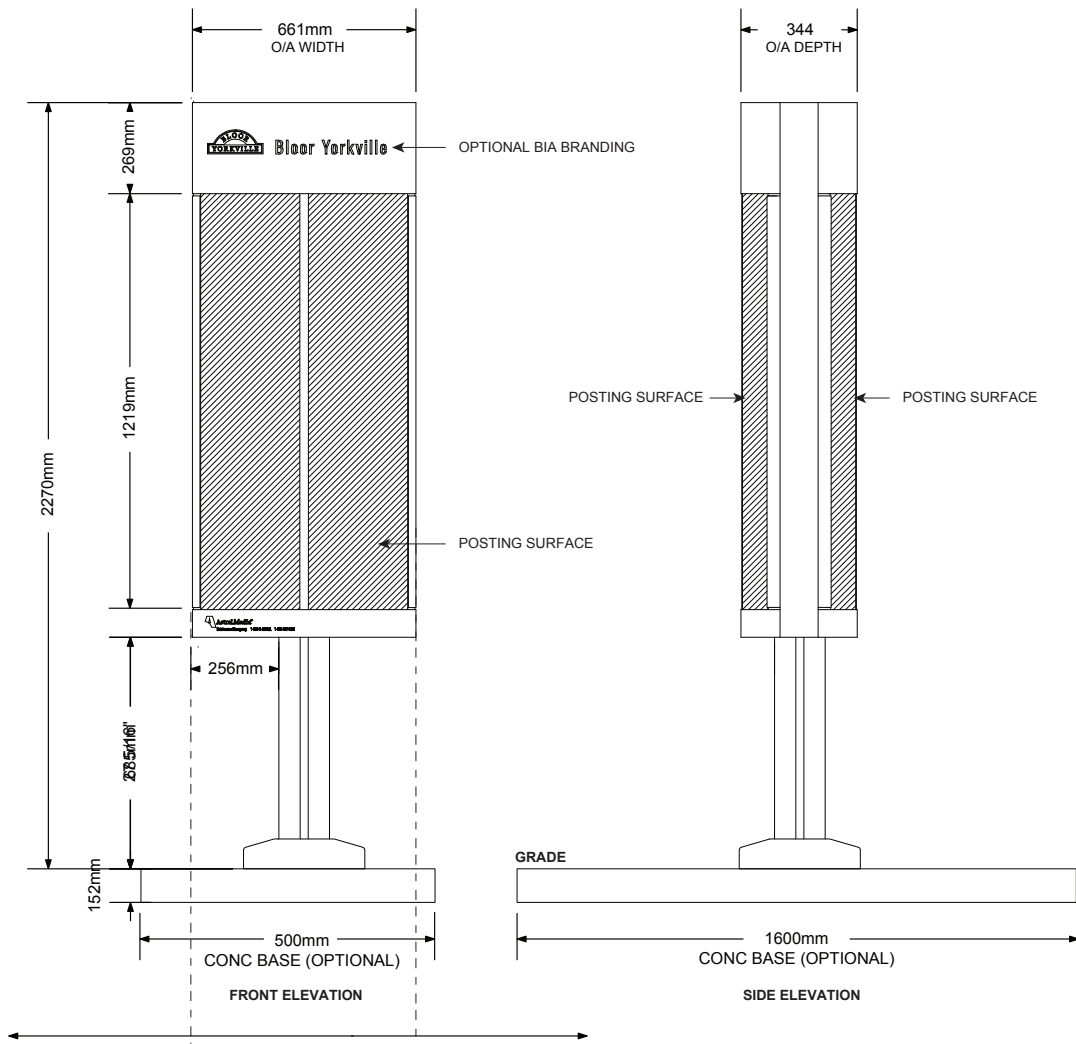

460mm MINIMUM CURB EDGE ZONE or SETBACK FROM SIDEWALK
MAINTAIN PEDESTRIAN CLEARWAY
(2100mm MINIMUM PREFERRED, 1700mm MINIMUM)

TORONTO 360°WAYFINDING STRATEGY

2.8 Wayfinding system components

The wayfinding strategy is built around a core family of on-street signage. The following illustrative products and content are proposed for Toronto. Detailed graphic and product design will be developed and tested in Phase Two.

Signage

▲ Gateway Totem

At gateways, such as major transit exits.
Content may include:

- Mode / system identification
- District and place name
- Strategic and local area directions
- Local area map
 - You are here (YAH)
 - 400-800m radius
 - Streets and sidewalks
 - Tier 1, 2, 3
- Context map
- Alternative media

▲ Context Totem

At or near major places of interest (Tier 1) and remarkable/significant areas of each district. Content may include:

- System identification
- District and place name
- Strategic directions towards adjacent districts and specific points within the local area
- Local area map
 - You are here (YAH)
 - 400-800m radius
 - Streets and sidewalks
 - Tier 1, 2, 3
- Context map
- Alternative media

■ Narrow Map Totem

At or near significant places of interest of each district and transit exits. Content may include:

- System identification
- District and place name
- Strategic and local area directions
- Local area map
 - 400-800m radius
 - Streets and sidewalks
 - Tier 1, 2, 3
- Context map
- Alternative media

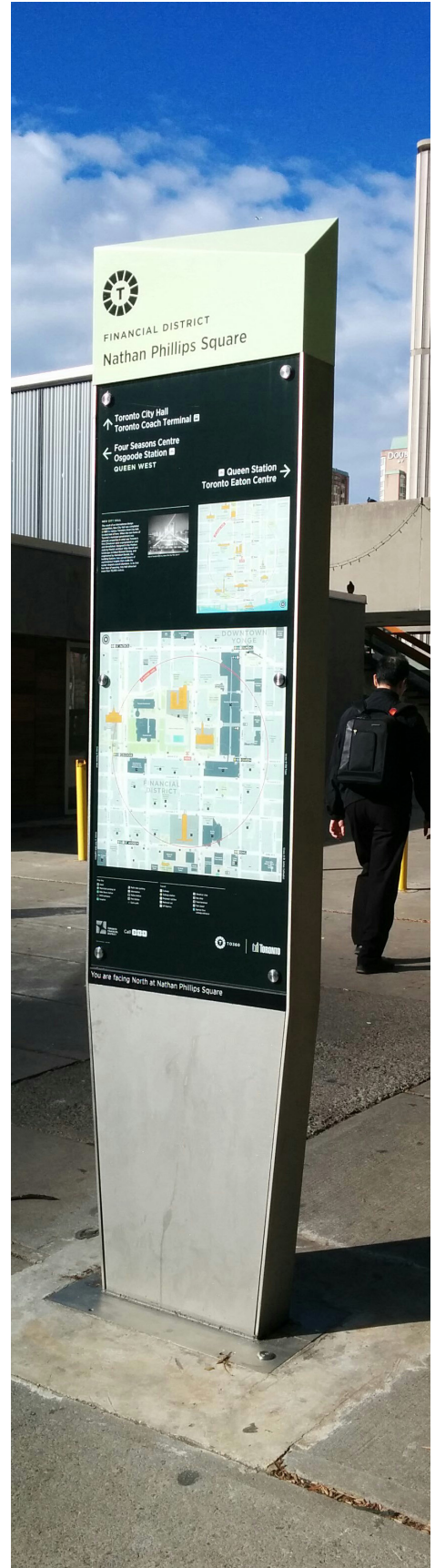
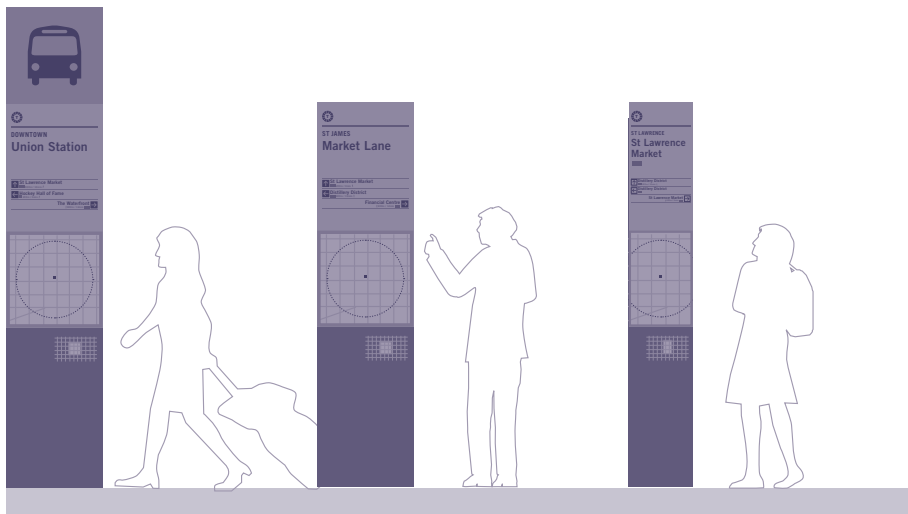

• FURNITURE •

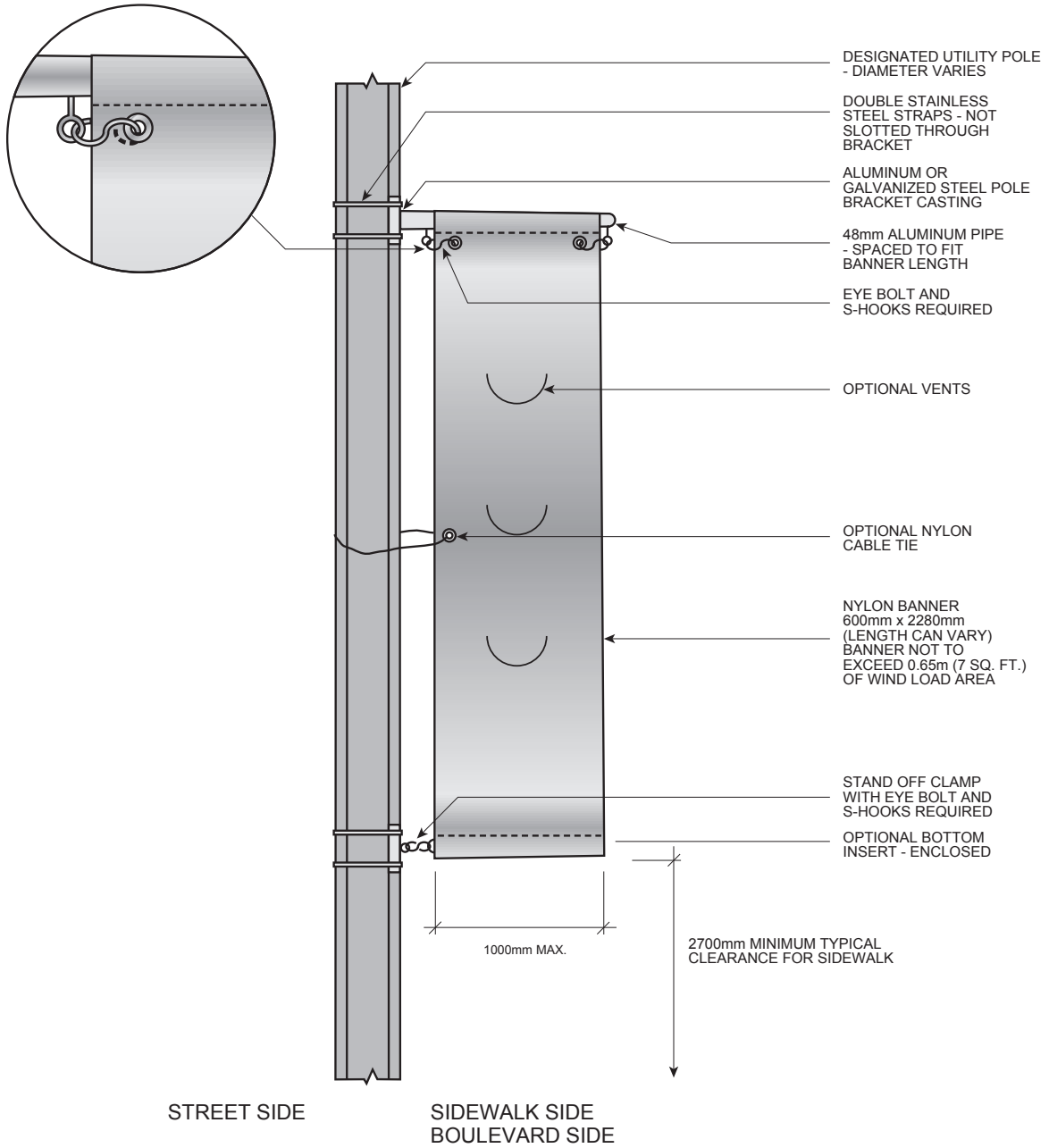

• LIGHTING •

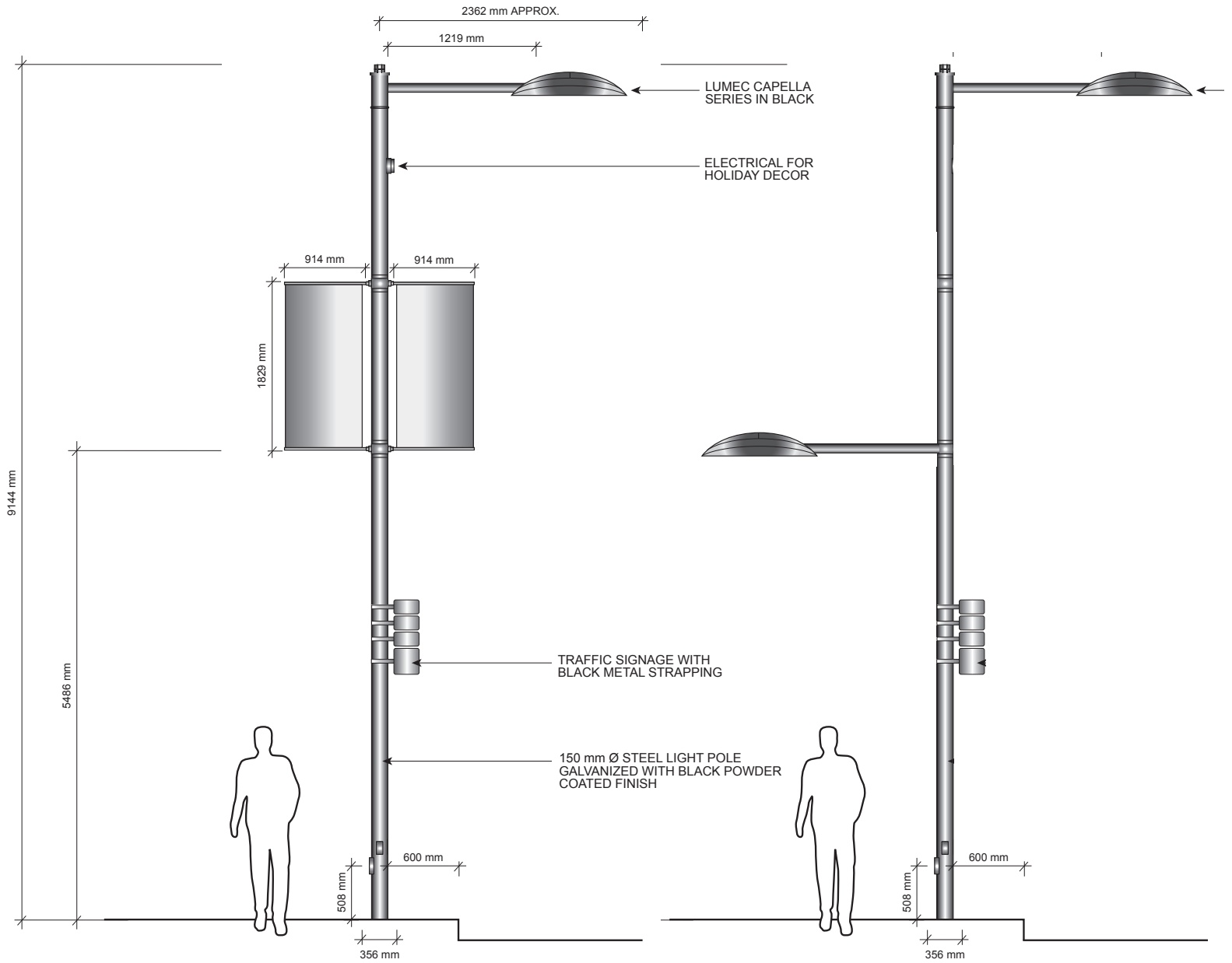

Toronto Urban Design

Streetscape Manual

Lighting - Street Light

 Economic Development, Culture & Tourism
Business Improvement Area Office

L-BIA42

NTS
11/08

• LIGHTING •

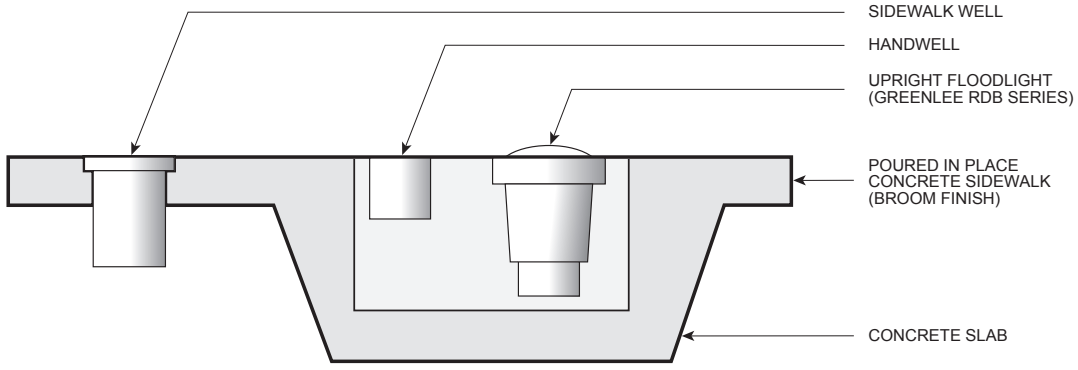

SECTION

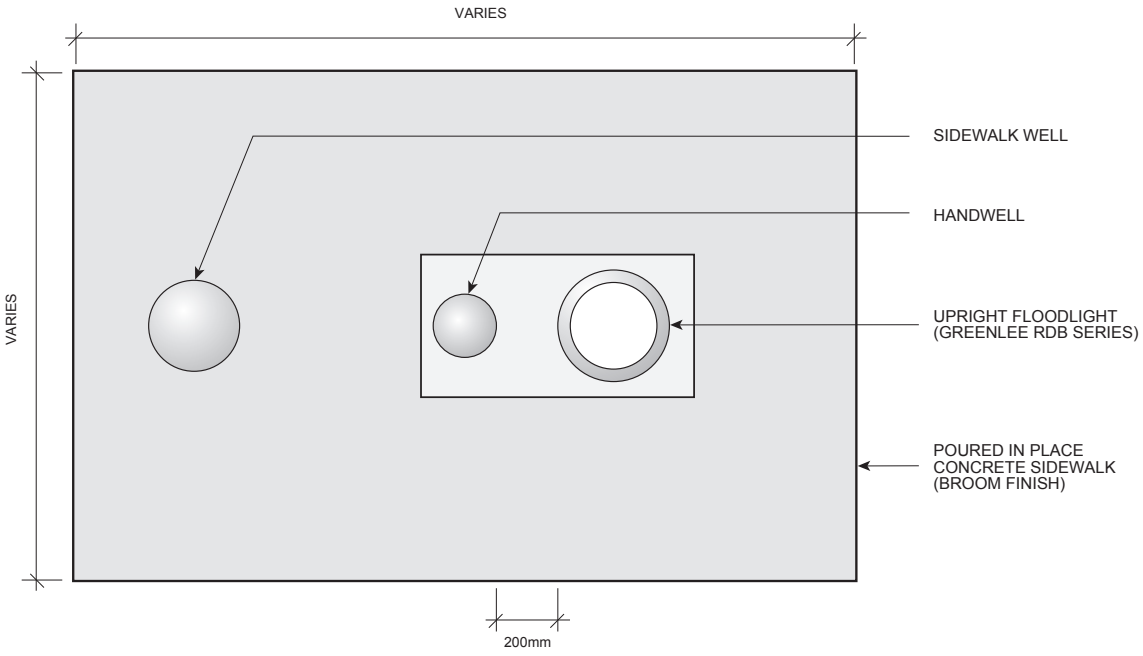

PLAN

The Flyer Graffiti Solution for Cityscape Beautification

Bella Wrap

Bella Wrap is a unique material that **attacks the bonding properties of adhesives associated with unsightly flyer graffiti.**

It's the perfect solution to deal with flyer-laden light poles, mail boxes and other public property.

Bella Wrap is **available in all shapes and sizes.** It works all year round to keep flyergraffiti at bay, beautifying cityscapes for locals and tourists alike.

Bella Wrap is also used as a **standalone branding medium.** It's a great solution for showcasing local events and civic pride.

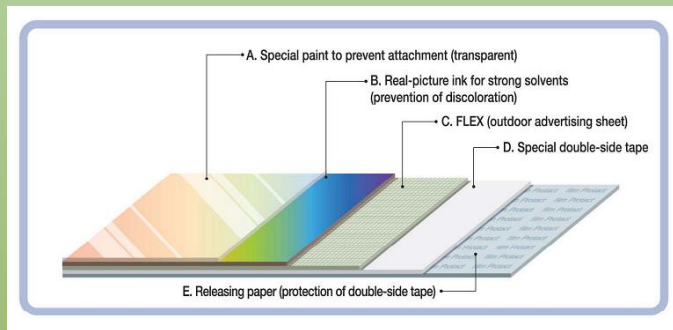

Bella Wrap: patented five-layer solution resists adhesives

Good-bye unsightly flyers!



Flyer Graffiti
Unsightly



Scraping
Unsightly



Bella Wrap
Beautification



www.streetgraffitisolutions.com

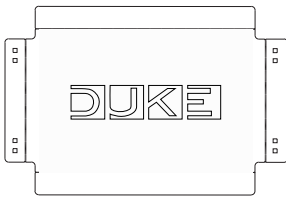

600 Module: Duke Heights Logo

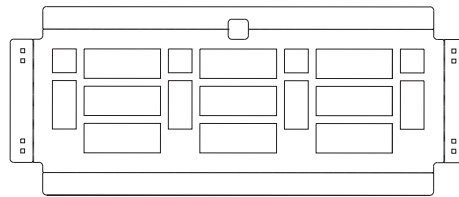

1200 Module: Picket Design

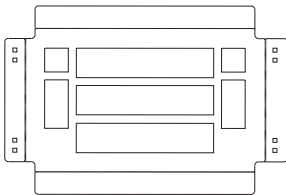

600 Module: Picket Design

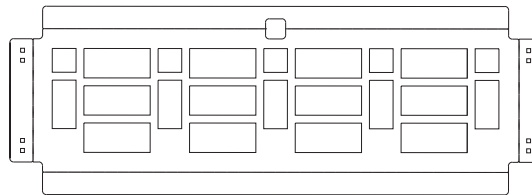

1400 Module: Picket Design

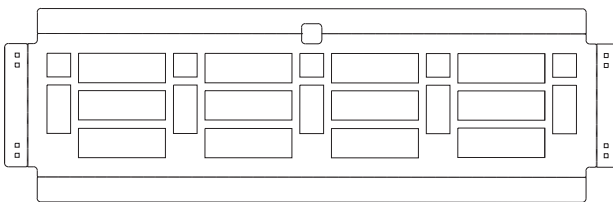

1600 Module: Picket Design

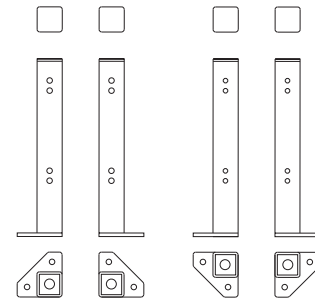

Post: Outer Left

Outer Right

Inner Left

Inner Right

• FURNITURE •

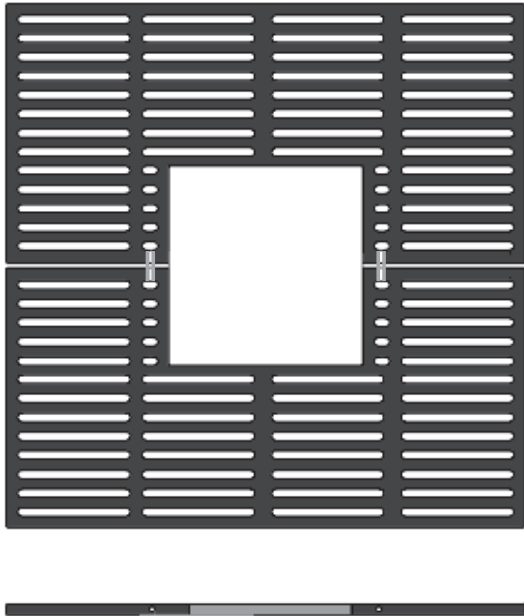

Trystan Model: TTO 4 TREE GRATE

NOTES:
THE FOLLOWING ARE IMAGES OF CUSTOM LANDSCAPE FURNISHINGS FOR THE TORONTO ENTERTAINMENT DISTRICT.
THESE FURNISHINGS ARE PROVIDED BY TRYSTAN FURNISHINGS OR AN APPROVED EQUAL.

Toronto Urban Design Streetscape Manual	1200 X 1200 Metal Tree Grate	 F-s15 NTS 10/12
--	------------------------------	---



CITY STANDARD UNIT PAVER - CHARCOAL COLOUR



CUSTOM CONCRETE JOINTING PATTERN



Toronto Street Trees

Guide to Standard Planting Options

City of Toronto

Urban Design Streetscape Manual

In collaboration with Parks, Forestry & Recreation



DRAFT





Table of Contents

<u>Introduction and Purpose</u>	1
<u>Growing Healthy Street Trees</u>	2
<u>Understanding the Streetscape</u>	3
<u>Streetscape Zones</u>	4
Planting Zones	5
<u>Standard Options for Street Tree Planting</u>	6
<u>Standard Options for Planting in Soft Landscapes</u>	7
T-sL1 Planting Between Curb and Sidewalk	
T-sL2 Planting Between Sidewalk and Property Line	
T-sL3 Planting Double Row of Trees	
<u>Standard Options for Planting in Hard Landscapes</u>	13
T-1 Open Planting Bed	
T-2 Raised Planter	
T-3 Planter Cover	
<u>Other Options for Planting in Hard Landscapes</u>	19
<u>Soft Landscape Spatial Requirements Fold-Out</u>	20
<u>Hard Landscape Spatial Requirements Fold-out</u>	21
<u>References</u>	22



Introduction and Purpose

Toronto has been known as the “City of Trees.” There are an estimated 10 million trees in the city’s public parks, ravines, natural areas, streets, squares and neighbourhoods. Collectively, these public and privately-owned trees form Toronto’s “urban forest.”

The importance of the urban forest is broad and includes such benefits as natural habitat, improved air quality, shade, stormwater control, pedestrian amenity and aesthetic beauty. The Toronto Official Plan, Toronto Green Standard and Parks, Forestry & Recreation’s Strategic Plan: Our Common Grounds, each identify the need to protect and expand the city’s urban forest with the goal of increasing the tree canopy coverage to between 30% and 40%—the recommended threshold to sustain a healthy urban forest.

To meet this tree canopy target in Toronto, it will require the City and property owners to protect and replace existing trees, as well as increase opportunities to plant new trees and nurture them to maturity.

In collaboration with Urban Forestry, the Urban Design Streetscape Manual provides a selection of standard design options for street tree planting in both soft and hard landscape conditions. The intent of these standard details is to encourage better tree planting environments and larger growing shade trees in the public right-of-way.

This document is a supplement to the Standard Tree Planting design details available in the Streetscape Manual. An outline of each standard option is accompanied by guidance on selecting the most appropriate design for the streetscape context.



Growing Healthy Street Trees

There are approximately 600,000 trees planted on Toronto’s streets. Although street trees currently represent a small proportion of the total tree canopy, they are extremely significant in their contribution to the quality of the urban environment. Increasing both the number and size of street trees in Toronto will not only benefit the urban forest, but also greatly enhance the livability of the city.

In order to plant street trees that mature and thrive, trees must be recognized as part of the city’s “infrastructure,” in much the same way that street lights, benches, litter bins, shelters and utilities are considered integral to a complete street. Sufficient space and conditions for successful tree planting must be secured throughout the design, planning and construction of all projects.

While many factors contribute to the health, size and longevity of a street tree, this guide focuses mainly on the preparation of the site and design of the planting environment. In particular, the following 5 key issues should be considered during the project planning and approval process:

1. ensuring adequate soil volume¹
2. providing good quality soil ²
3. coordinating with the location of above and below-grade utilities
4. providing adequate watering³ and proper drainage
5. establishing maintenance routines and responsibilities
(pruning, pest control, weeding, watering, litter removal, etc.)

Notes:

¹ At least 15m³ of high quality soil should be provided per tree and each tree (through sharing or alone) should have direct access to at least 30m³ of high-quality soil.

² High-quality soil shall consist of a minimum 0.9m and maximum 1.2m depth, over and above any required drainage system and/or granular material, be uncompacted, and be sandy loam with the following composition:

- Sand (50%-60%)
- Silt (20%-40%)
- Clay (6%-10%)
- Organic (2%-5%)
- pH = 7.5 or less

³ Especially within the first 2 years of establishment

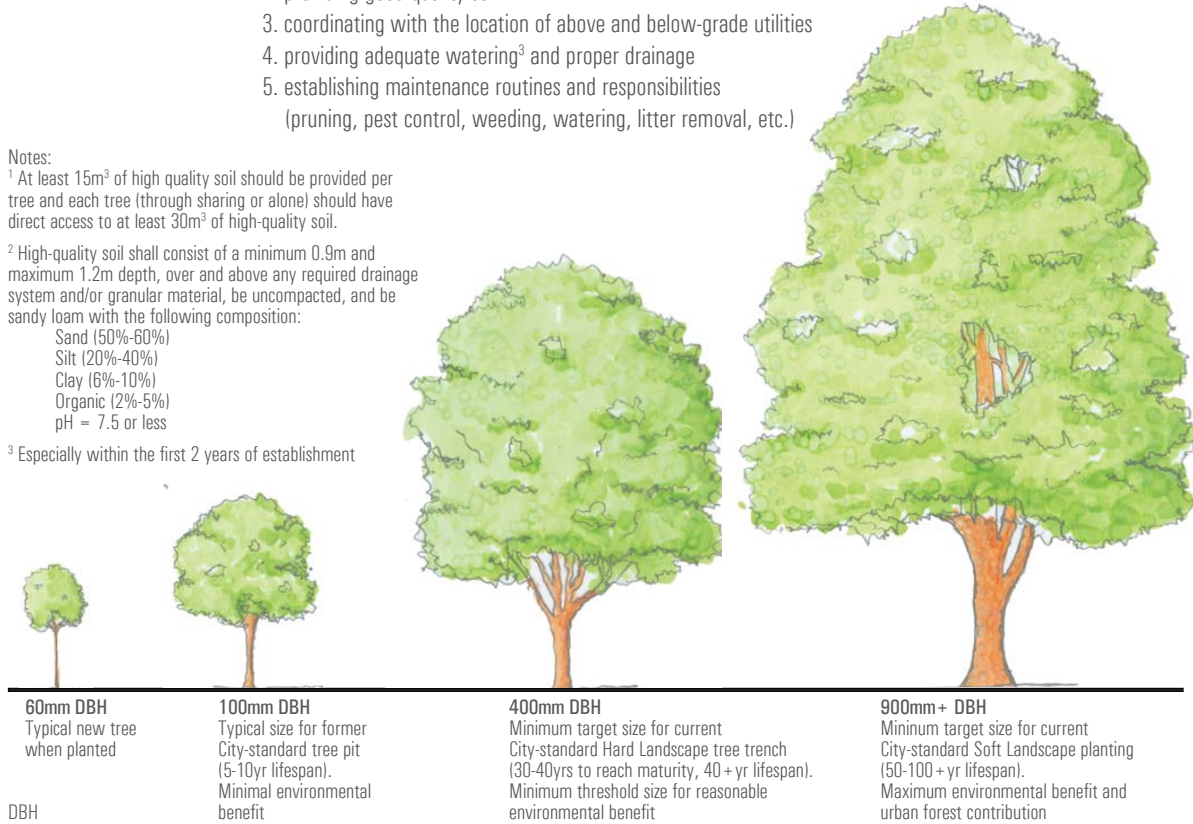

DBH
Diameter at breast height



Understanding the Streetcape

Toronto has a wide range of streets in both urban and suburban contexts. While most suburban streetscapes are generous in scale with ample space to plant trees, urban streetscapes can be more congested with a host of competing needs, such as street-front buildings, markets, outdoor cafés, street furnishings, underground and overhead utilities, bicycle parking and pedestrian traffic, all of which make successful street tree planting a greater challenge.

The Streetscape Manual identifies two general types of street: Green Streets and Main Streets. Green Streets are most closely associated with a suburban or residential context and offer many opportunities for low-cost, soft landscape tree planting. Main Streets, which are more commonly found in the denser urban centres and along avenues, are vibrant places, but may also require more costly and engineered tree planting solutions.

The Manual sub-divides Green Streets and Main Streets into the below listed hierarchy of streetscape types. This hierarchy helps assign appropriate design treatments to reflect the character and significance of each Toronto street.

STREETSCAPE TYPES*

Green Streets

- Scenic
- Intermediate

Main Streets

- Special
- Major
- Existing Main
- Emerging Main

*visit the Streetscape Manual online for more information about each streetscape type
INTERNAL STAFF ACCESS ONLY from city-dev.toronto.ca/planning/urbdesign/streetscape/

The Streetscape Manual focuses primarily on enhancing the design quality of the city's arterial road network. Although many local neighbourhood streets are not identified in the Manual, tree planting remains a high priority for these streetscapes (refer to the design options recommended for Planting in Soft Landscapes (T-sL) for these streets).

Streetscape Zones

Typical Streetscape Zones: Green Street

Each streetscape type can be readily understood as a series of active use areas or “zones.” The space between the curb and property line is the most common place for trees within the public right-of-way and is the area of focus in the Manual.

Although the design treatments may appear quite different between Green Streets and Main Streets, both streetscape types share a common structure of functional zones:

1. Edge Zone / Curb Apron

- Located next to roadway/curb
- Provides buffer between vehicles and pedestrians
- Accommodates car door swing, mirrors, trash bin collection and snow windrows
- Typically 0.46m min. from curb face is kept clear of permanent installations (e.g. street furnishings)

2. Furnishing and Planting Zone

- Adjacent to edge zone and/or property line
- May contain street trees, street furniture, poles, light standards and other fixed objects
- In some cases may contain boulevard cafés and other marketing activities (see #4. below)
- Width varies, but elements should be aligned in a manner that does not obstruct Pedestrian Clearway

3. Pedestrian Clearway

- Accommodates primary pedestrian movement
- A clear, unobstructed path with a reasonable width (2.1m min. recommended) to serve pedestrian flow
- Provision of the Clearway is a priority
- Trees, lighting, weather protection may extend above Clearway provided vertical clearance of 2.1m min.

4. Frontage and Marketing Zone

- Adjacent to building/property line
- May consist of marketing, outdoor merchandise displays, boulevard cafés and/or landscaping
- In some cases may support street furniture and/or trees

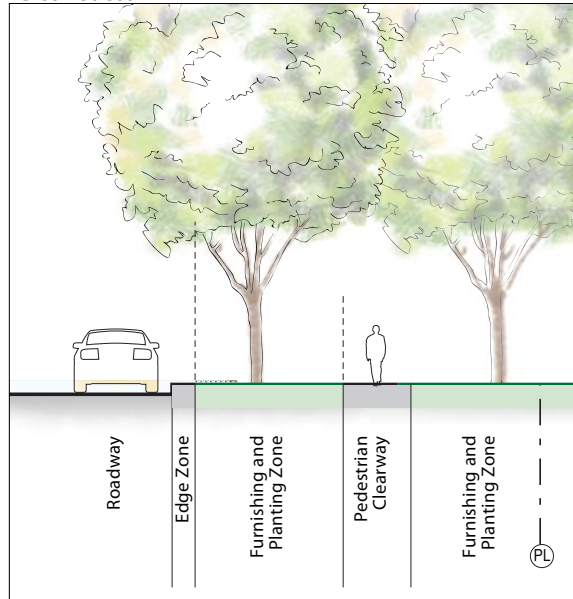

Typical Streetscape Zones: Main Street

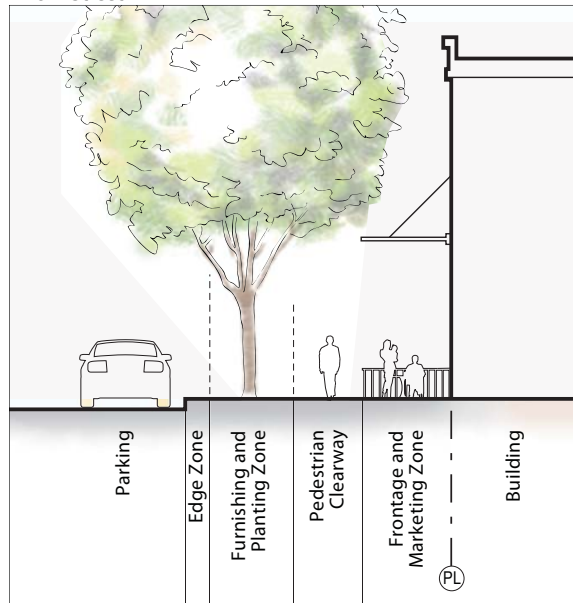

Toronto Street Trees

Planting Zones

GREEN STREETS

Green Streets are characterized by generous landscaped setbacks, adjacent natural areas, public parks and open spaces. The built elements within these streetscapes are integrated with the natural environment and enhanced with street tree planting, creating open space corridors with a naturalized form.

Tree planting on Green Streets is typically within a soft landscape: refer to T-sL design details for standard tree planting options.

Less often, hard landscape treatments may be required: refer to T-design details for standard planting options.



MAIN STREETS

Main Streets normally include commercial, residential and mixed-use buildings which generate grade-related activities. The buildings create a continuous street wall with a direct or 'storefront' relationship to both the pedestrian realm and the vehicular portion of the street.

Tree planting on Main Streets is most often in a hard landscape treatment (curb surround, raised planter, etc.): refer to T- design details for standard tree planting options. Other tree planting systems (e.g. soil cells, breakout corridors) may be used subject to City approval (refer to page 19).

In rare cases, e.g. emerging main streetscapes, soft landscape treatments may be appropriate: refer to T-sL design detail for standard planting options.





Standard Options for Street Tree Planting

The following City of Toronto standard tree planting options for the public right-of-way should be referenced and applied during all streetscape-related projects, including:

- City Planning Development Review (e.g. Site Plan Applications)
- City Road Reconstruction Projects (Initiated by Transportation Services and TTC)
- Business Improvement Area Streetscape Enhancements Programs
- Urban Forestry Operations and Maintenance Projects
- Other Public and Private Streetscape-Related Construction/Enhancement Projects

The Street Tree planting options presented in this guide are classified in two categories: soft landscape and hard landscape. Selection of the appropriate option depends on the Streetscape Type (Main or Green) and the available space for the planting zone.

Soft Landscape Planting Options:

T-sL1 Planting between Curb and Property Line

T-sL2 Planting between Sidewalk and Property Line

T-sL3 Planting Double Row of Trees

Hard Landscape Planting Options: 1830mm Continuous Soil Trench



T-1 Open Planting Bed with curb surround

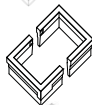

T-2 Raised Planter



T-3 Planter Cover



Continuous soil trench under construction

Other Hard Landscape Planting Options

Alternative design solutions, which provide comparable or better growing conditions, may be considered subject to City approval. Refer to page 19 for design strategies and considerations.

T-sL1 Planting Between Curb and Sidewalk



Description

In design option T-sL1, trees are planted between the curb/roadway and sidewalk. The surrounding planting area is grass and mulch (City Standard) or other soft landscape planting (approved by City and maintained by others).

Design Application

Most typically applied on GREEN STREETS.

Positive attributes

- Defines street edge
- Shades both street and pedestrian clearway
- Buffers pedestrians from street traffic
- Appropriate where little or no setback
- Provides space for canopy to spread evenly, tree achieves more natural shape – less maintenance
- May permit double row of trees, second row may be on public or private property (see also T-sL3)

Issues to consider

- Location of overhead and underground utilities
- Continuity of pedestrian clearway from adjacent sites/blocks
- Opportunities to bridge soil/rooting area under sidewalk, driveways and other surrounding surfaces
- Road snow storage kept away from pedestrian clearway, but may negatively impact health of trees (depending on distance trees are planted from curb)
- Trees may experience greater stress from road related activities: salt, snow, pollution, compaction, etc.

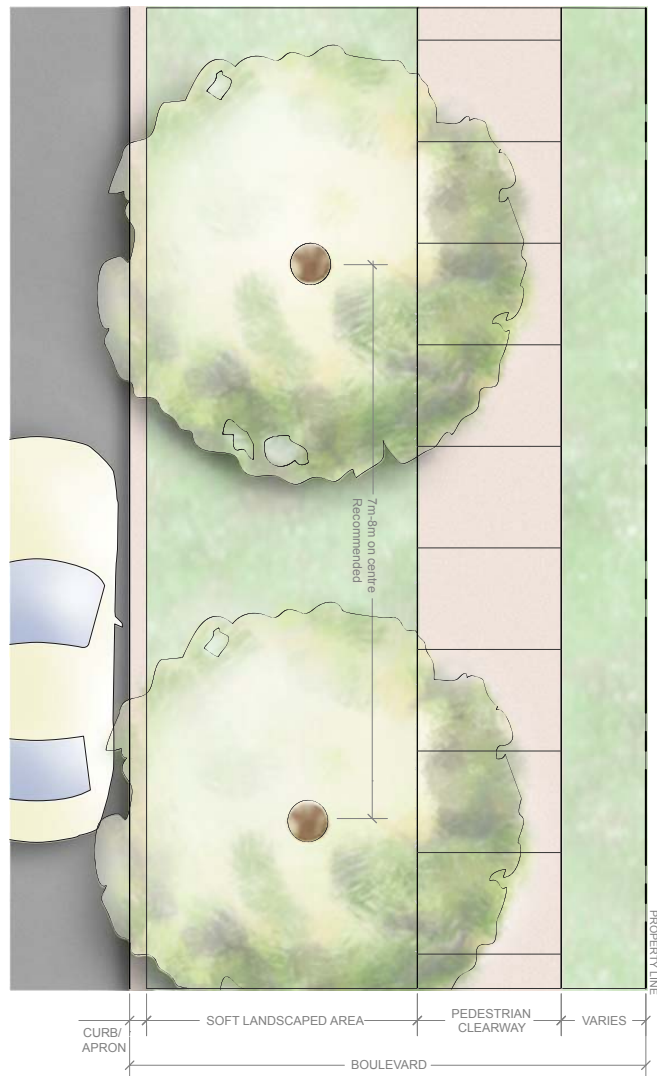

Typical Plan View for Planting Option T-sL1



Typical Cross-Section and Space Requirements for Planting Option T-sL1

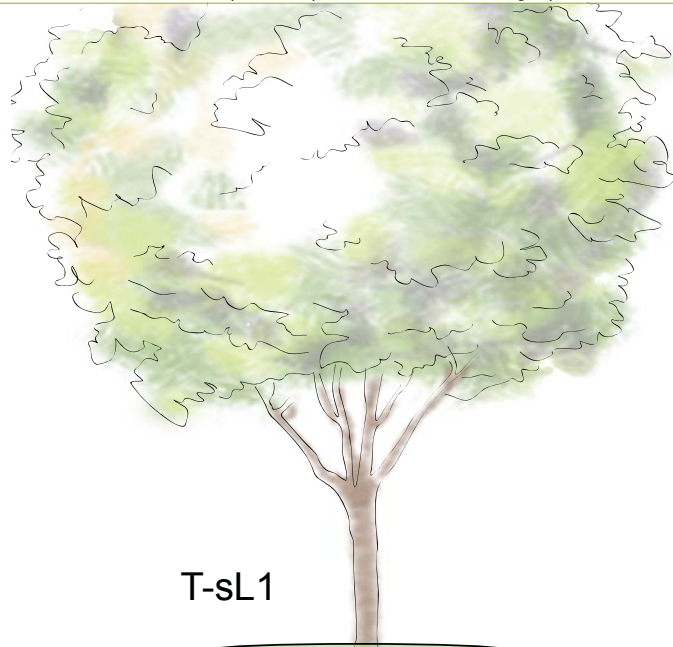

CURB	SOFT LANDSCAPE AREA	PEDESTRIAN CLEARWAY	MINIMUM TOTAL WIDTH REQUIRED
0.2m	5.5m	2.1m	7.80m
		1.7m	7.40m
		1.53m	7.23m
0.2m	3.2m	2.1m	5.50m
		1.7m	5.10m
		1.53m	4.93m
0.2m	2.0m*	2.1m	4.30m
		1.7m	3.90m
		1.53m	3.73m

Note:

* Minimum required width varies depending on growing conditions available within the boulevard and/or beyond the property line. See Planting Options: Soft Landscape | Spatial Requirements fold-out at back of this guide for more detailed specifications.

T-sL2 Planting Between Sidewalk and Property Line



Description

In design option T-sL2, trees are planted between the sidewalk and property line. The surrounding planting area is grass and mulch (City Standard) or other soft landscape planting (approved by City and maintained by others).

Design Application

Most typically applied on GREEN STREETS.

Positive attributes

- Shades pedestrian clearway
- Potential for tree roots to readily utilise additional soil volume on adjacent private properties
- Buffers tree from road activity stresses (e.g. salt spray, snow windrows, pollution, etc.)

Issues to consider

- Location of overhead and underground utilities
- Continuity of pedestrian clearway from adjacent sites/blocks
- Coordination with street furniture placement
- Requires building setback to permit full canopy - otherwise risk of greater maintenance
- May impact/conflict with or may enhance marketing zone activities (coordination required)
- Pedestrian clearway more exposed to traffic and roadway activities
- May cause uncertainty about ownership and maintenance responsibilities

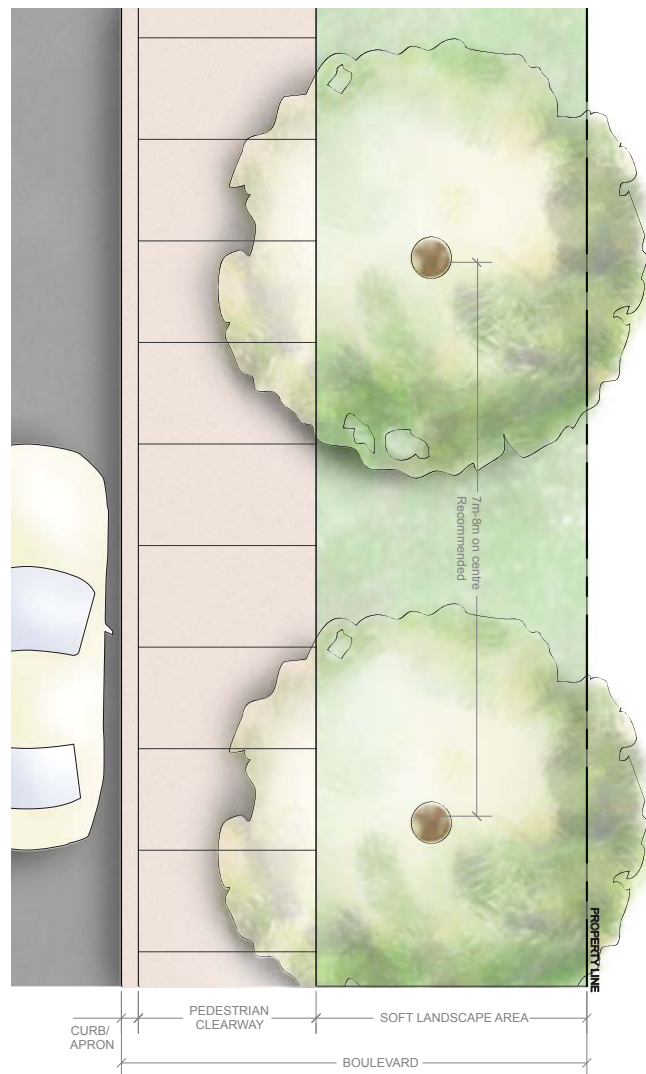

Typical Plan View for Planting Option T-sL2



Typical Cross-Section and Space Requirements for Planting Option T-sL2



T-sL2

CURB	PEDESTRIAN CLEARWAY	SOFT LANDSCAPE AREA	MINIMUM TOTAL WIDTH REQUIRED
0.2m	2.1m	3.2m	5.50m
	1.7m		5.10m
	1.53m		4.93m
0.2m	2.1m	2.0m*	4.30m
	1.7m		3.90m
	1.53m		3.73m
0.2m	2.1m	1.5m**	3.80m
	1.7m		3.40m
	1.53m		3.23m

Note:

* / ** Minimum required widths vary depending on growing conditions available within the boulevard and/or beyond the property line. See Planting Options: Soft Landscape | Spatial Requirements fold-out at back of this guide for more detailed specifications.

T-sL3 Planting Double Row of Trees



Description

In design option T-sL3, street trees are planted in a double row to one side or on either side of the sidewalk. The surrounding planting area is grass and mulch (City standard) or other soft landscape planting (approved by City and maintained by others). This planting option combines the requirements of T-sL1 and T-sL2.

Design Application

Most typically applied on GREEN STREETS, but only suitable for wider boulevards where both planting environments can be equally supportive of healthy, mature trees. Private property may augment planting conditions where available.

Positive attributes

- Combines benefits of T-sL1 and T-sL2 (see previous pages)

Issues to consider

- Refer to issues for T-sL1 and T-sL2
- Stagger trees and space evenly for maximum canopy effect
- Use only where sufficient width exists. The quality of planting conditions should not be compromised to accommodate a double row (i.e. high-quality single row preferred)
- On narrower boulevards, similar effect possible using option T-sL1 and planting a second row of trees on private property

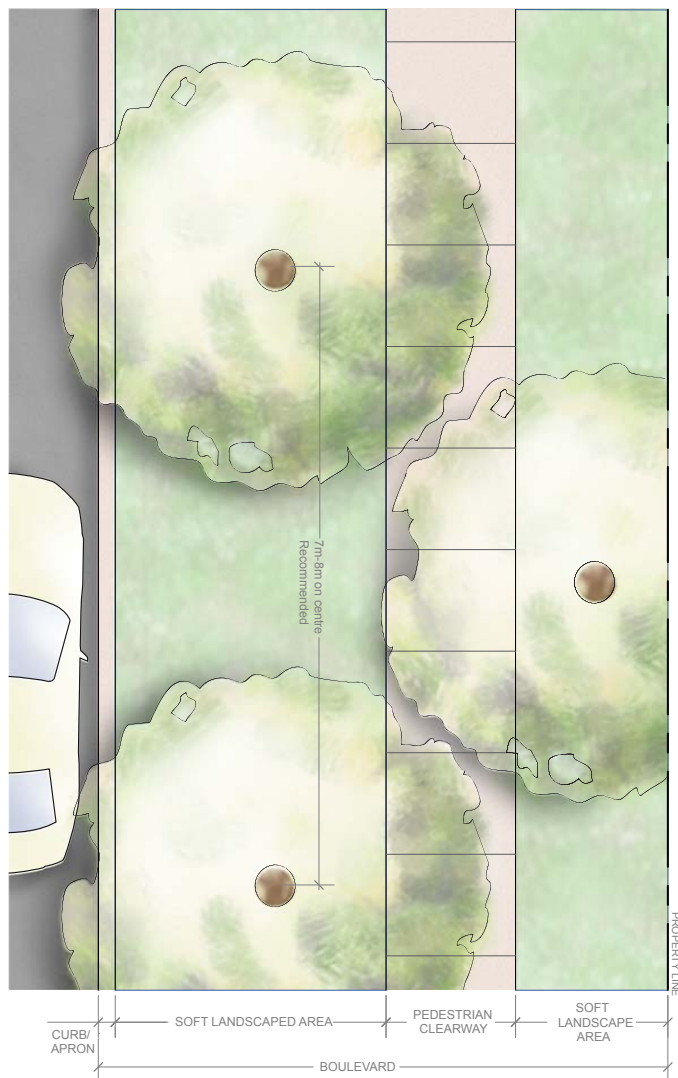

Typical Plan View for Planting Option T-sL3



Typical Cross-Section and Space Requirements for Planting Option T-sL3



T-sL3

CURB	SOFT LANDSCAPE AREA	PEDESTRIAN CLEARWAY	SOFT LANDSCAPE AREA	MINIMUM TOTAL WIDTH REQUIRED
		2.1m		11.00m
0.2m	5.5m	1.7m	3.2m	10.60m
		1.53m		10.43m
		2.1m		8.70m
0.2m	3.2m	1.7m	3.2m	8.30m
		1.53m		8.13m
		2.1m		7.00m
0.2m	3.2m	1.7m	1.5m*	6.60m
		1.53m		6.43m

Note:

* Minimum required width varies depending on growing conditions available within the boulevard and/or beyond the property line. See Planting Options: Soft Landscape | Spatial Requirements fold-out at back of this guide for more detailed specifications.

T-1 Open Planting Bed

T-1 Option for 1830mm Continuous Soil Trench



T-1A-Concrete Sidewalk / T-1B-Unit Paved Sidewalk

Description

In design option T-1, street trees are planted in an open bed surrounded by mulch (City Standard) and/or low plantings (maintained by others) and a barrier curb. The curb treatment may be granite, precast concrete, or other City-approved material.

The length of the open planting bed varies depending on the sidewalk space available (1800mm minimum, normally increased in 1800mm increments). The open planting bed must be completely soft surface and/or protected with a railing/bollards to ensure pedestrians do not interpret it as a sidewalk.

The curb profile also varies, but should always provide a clear definition between the pedestrian clearway and the planting area.

A variety of furnishings, such as decorative railings, bollards, tree guards, etc. may be installed where approved by the City and maintained by others (e.g. local Business Improvement Area, property owner, etc.) unless otherwise specified.

Design Application

The Open Planting Bed is most typically applied on MAIN STREETS with generous sidewalks. Each planting bed accommodates single or multiple trees

Positive attributes

- Open planting bed gives tree roots greater access to water and air
- Root crown has more room to grow and spread without disturbing surrounding hard surface or girdling tree
- Soft surface increases stormwater and pollution control benefits for sidewalk
- Plant material (normally maintained by others) enhances streetscape appearance
- Barrier curb/plantings protect trees from injury related to sidewalk activities (e.g. snow plowing, salting, pedestrian traffic, bicycle storage, etc.)

Issues to consider

- Continuity of pedestrian clearway from adjacent sites/blocks (trench may be located next to edge zone as shown or between clearway and property line where building setbacks permit)
- Coordination with street furniture placement and utility locations
- Only appropriate where clearway is wide enough for pedestrians to circulate without treading on curb or planted area (2.1m minimum required)
- Ideal where adjacent property owner/Business Improvement Area or City/ others agree to maintain enhanced plant material and/or decorative features



Optional decorative protective railing



Total Required Sidewalk Width

- 4.8m minimum (with 2100mm clearway)

Note: Where decorative paving band is replaced with 400mm min. wide curb, required minimum width reduced to 4.4m

Continuous Trench

- 1830mm width

Curb / Apron

- width varies (815mm typical, 400mm minimum)

Pedestrian Clearway

- width varies (2100mm minimum)

Tree Spacing

- plant on-centre 5.0m min. to 10.0m max.
(7.0m to 8.0m intervals recommended)

See Planting Options: Hard Landscape | Spatial Requirements fold-out at back of this guide for more detailed specifications.

T-1B - Unit Paved Sidewalk Option

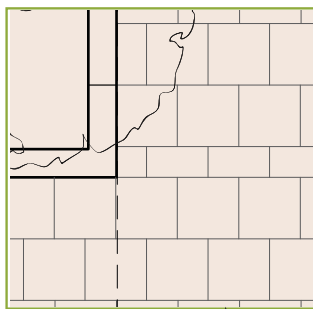

Curb Apron

Continuous Trench

Pedestrian Clearway

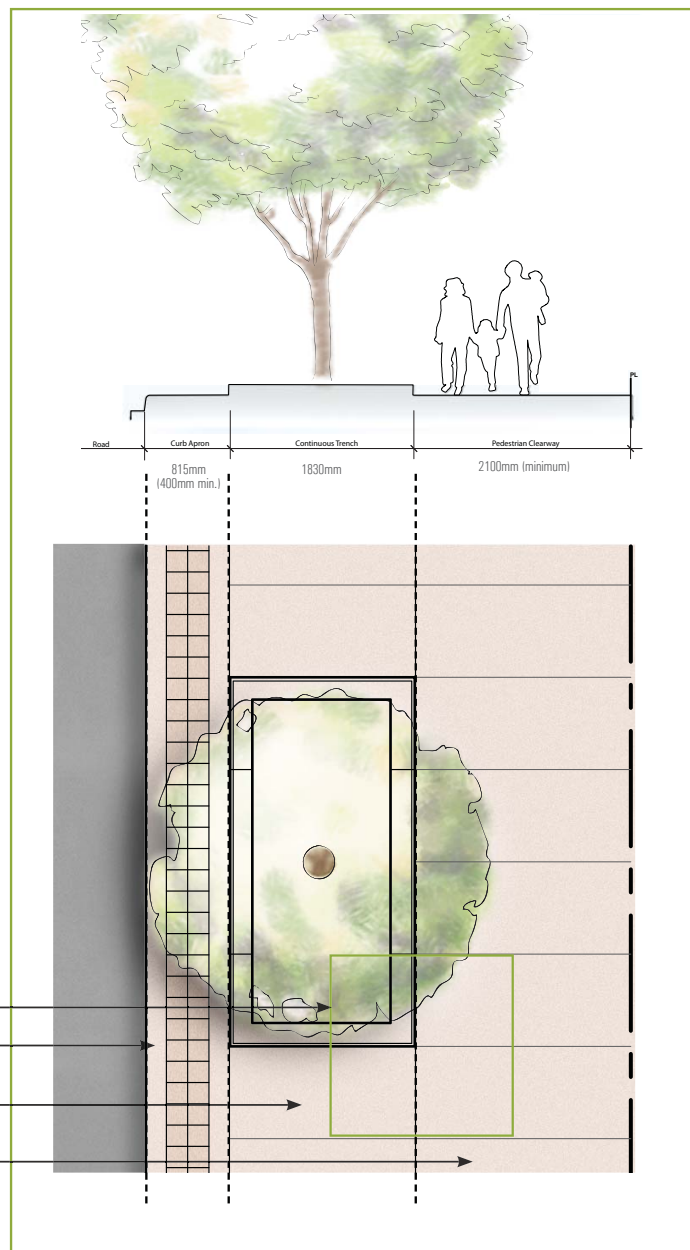

T-2 Raised Planter

T-2 Option for 1830mm Continuous Soil Trench

T-2A-Concrete Sidewalk / T-2B-Unit Paved Sidewalk

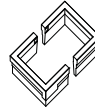

Description

In design option T-2, street trees are planted in a raised planter surrounded by mulch (City Standard) and/or low plantings (maintained by others). The top ledge of the planter may also function as a seat with optional treatment in granite, wood, or other City-approved material (see typical options below right).

Design Application

Most typically applied on MAIN STREETS with wide sidewalks and generous building setbacks. Although narrower applications are possible, a minimum distance of 6m between the tree and building face is recommended.

Positive attributes

- Same benefits as for T-1 (see previous pages)
- Raised bed provides additional protection for trees from road and sidewalk activities (i.e. less exposure to salt spray, snow piling, compaction, etc.)
- Informal seating ledges enhance streetscape amenity

Issues to consider

- Continuity of pedestrian clearway from adjacent sites/blocks (trench may be located next to edge zone as shown or between clearway and property line where building setbacks permit)
- Coordination with street furniture placement and utility locations
- Only appropriate where clearway is wide enough for pedestrians to circulate comfortably (2.1m minimum required, more width required on busy streets)
- Ideal where adjacent property owner/Business Improvement Area or City/ others agree to maintain enhanced plant material, seat cladding and other decorative features (see optional identification detail below)



Planter Top Typical Options Granite, Wood, Concrete, or As Specified

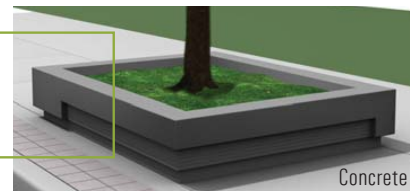
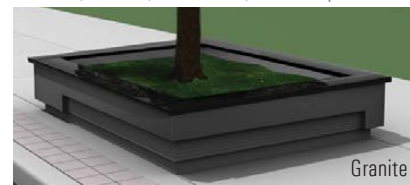

Optional BIA/Neighbourhood Identification Material and Design as approved by City

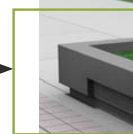
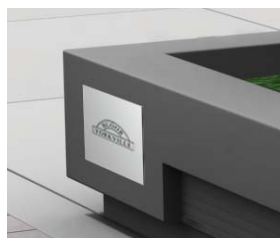



Total Required Sidewalk Width

- 4.8m minimum (with 2100mm clearway)

Note: Where decorative paving band is replaced with 460mm minimum setback of planter edge from curb, required minimum width reduced to 4.5m

Continuous Trench

- 1830mm width (1930mm with planter overhangs)

Curb / Apron

- width varies (765mm* typical, 460mm minimum to planter edge)

Pedestrian Clearway

- width varies (2100mm minimum)

Tree Spacing

- plant on-centre 5.0m min. to 10.0m max. (7.0m to 8.0m intervals recommended)

See Planting Options: Hard Landscape | Spatial Requirements fold-out at back of this guide for more detailed specifications.

T-2B- Unit Paved Sidewalk Option

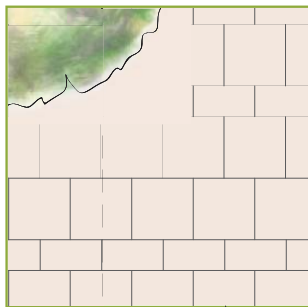

 Curb Apron

 Continuous Trench

 Pedestrian Clearway

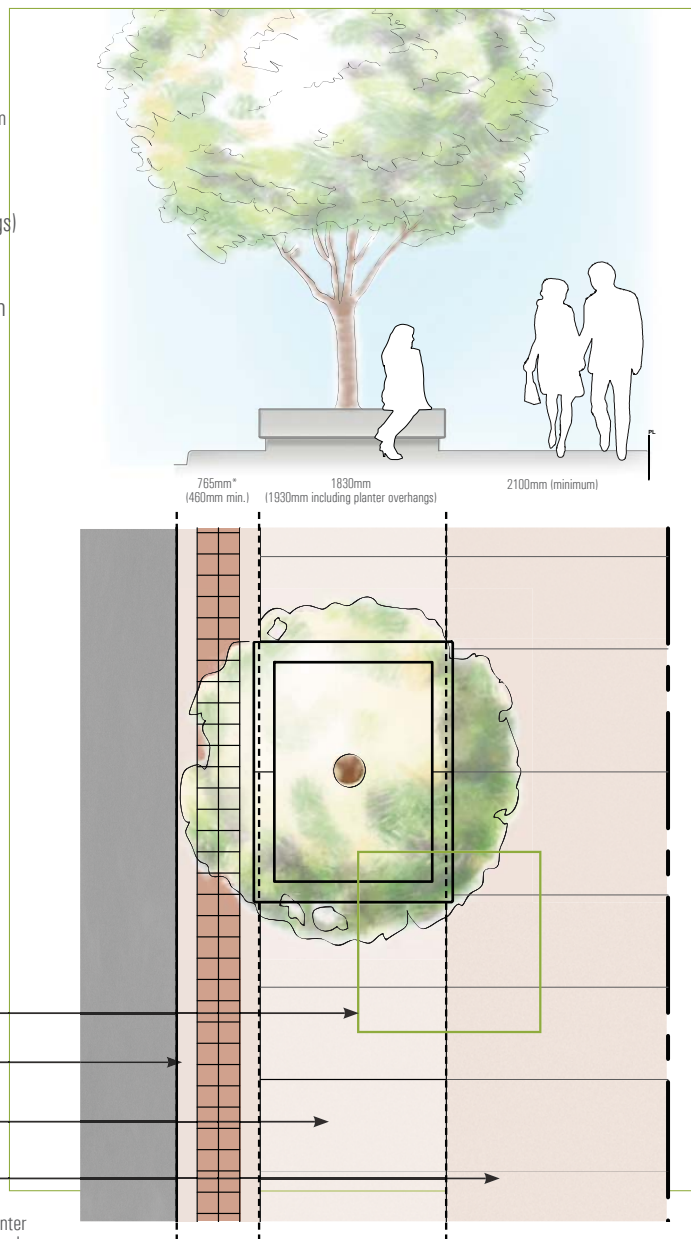

*765mm represents typical distance between the curb and planter edge based on an 815mm curb apron with a two row paver band

T-3 Planter Cover

T-3 Option for 1830mm Continuous Soil Trench



T-3A-Concrete Sidewalk / T-3B-Unit Paved Sidewalk

Description

In design option T-3, street trees are planted below a hard surface cover (precast concrete or unit pavers typical) with a 600mm x 600mm tree opening. A metal tree grate (as approved by the City and maintained by others) may be installed in place of the hard surface cover (see below). The tree opening should be protected with a tree grid, tree guard, planting basket, or other City-approved installation.

Design Application

Most typically applied on MAIN STREETS with narrow sidewalks, extensive marketing activities (e.g. outdoor cafés, grocery stands, etc.) and/or little to no building setbacks.

Positive attributes

- Provides tree growing opportunity in constrained sidewalk environments
- Planter cover maximizes available space for pedestrian circulation
- Tree roots protected from compaction related to pedestrian activity
- Optional guard may further protect tree from injury related to sidewalk activity (e.g. snow removal, bicycle storage, etc.)

Issues to consider

- Continuity of pedestrian clearway from adjacent sites/blocks (trench may be located next to edge zone as shown or between clearway and property line where building setbacks permit - consider using planting option T-1 where building setback allows additional clearway to be secured on private property)
- Coordination with street furniture placement and utility locations
- Only recommended where sidewalk zone, clearway and building setbacks are too narrow or crowded to accommodate planting detail T-1 (see previous pages)



Optional protective tree grate being installed

Optional Tree Grate (to replace hard cover) Material and Design as approved by City

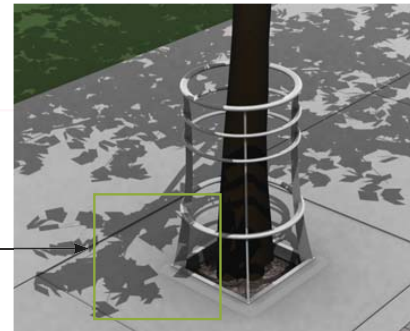

Optional protective tree guard



Total Required Sidewalk Width

- 4.8m minimum (with 2100mm clearway)
- 4.2m minimum (with 1530mm clearway)

Note: Where decorative paving band is replaced with 400mm min. wide curb, required widths reduced to 4.4m and 3.8m

Continuous Trench

- 1830mm width

Curb / Apron

- width varies (815mm typical, 400mm minimum)

Pedestrian Clearway

- width varies (2100mm preferred* minimum, 1530mm absolute minimum)

*where 2100mm+ clearway achieved, consider using T-1

Tree Spacing

- plant on-centre 5.0m min. to 10.0m max. (7.0m to 8.0m intervals recommended)

See Planting Options: Hard Landscape | Spatial Requirements fold-out at back of this guide for more detailed specifications.

T-3B- Unit Paved Sidewalk

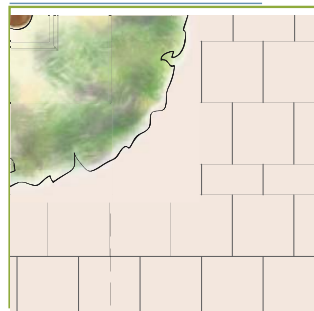

- Curb Apron
- Continuous Trench
- Pedestrian Clearway

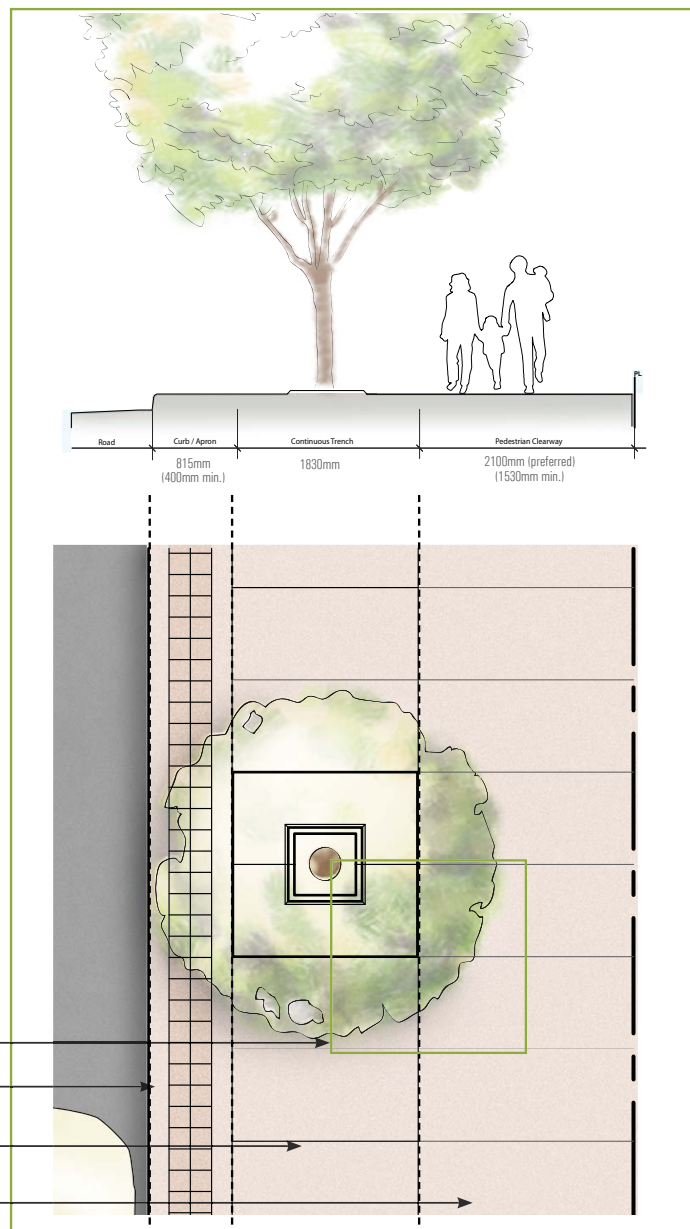



Other Hard Landscape Planting Options

OTHER STRUCTURAL SYSTEMS

Alternative design solutions, which provide comparable or better growing conditions (i.e. 30m³ min. of high-quality soil for each tree, see page 2), may be considered subject to City approval.

It is appropriate to consider the use of other structural systems (poured-in-place curbs, suspended slabs, structural soils/cells, etc.) where budget permits and/or conditions above- and below-grade prohibit the application of current City Standards. Alternative structural systems can also be used to augment the City's standard options or other approved designs.

STRUCTURAL SOIL CELLS

One advantage of soil cells over the current City planting standards is that a significant growing environment can be achieved within a more flexible underground configuration. The depth of the cells can vary according to each modules' width and height and the layout of soil volume can cover an irregular area (not limited by structural spans or a linear footing). This flexibility increases growing opportunities particularly in constrained areas.

When and how should structural cells be used?

Option A. Bridging Soil Volumes

Use between planting areas to provide bridging connections below hard surfaces from one soil volume to another. Used in this way, soil cells provide a means to connect isolated trees to an adequate growing environment (note: structural soils or reinforced sidewalks can also be used to achieve bridging).

Option B. Expanding Soil Volumes

Use to expand the soil volume of trees planted in a contained planting area which is not large enough to provide optimum tree growing conditions. Used in this way, soil cells extend the soil volume laterally beyond the planting bed below areas traditionally unsuitable for tree growth (sidewalks, parking lay-bys, etc.).

Option C. Providing Soil Volumes

Apply in high profile areas where space for tree planting is limited, constrained by underground utilities, building setbacks or pedestrian traffic. Soil cells provide an opportunity for a wide range of surface treatments, while still providing sufficient soil volume below to allow trees to reach maturity.

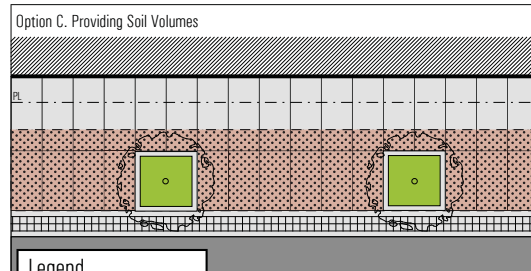
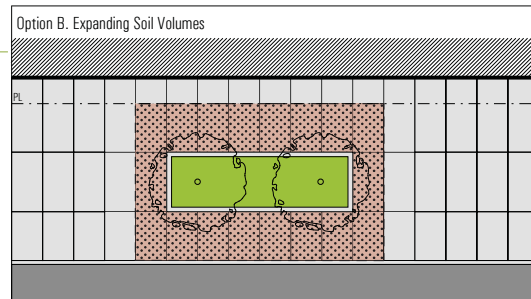
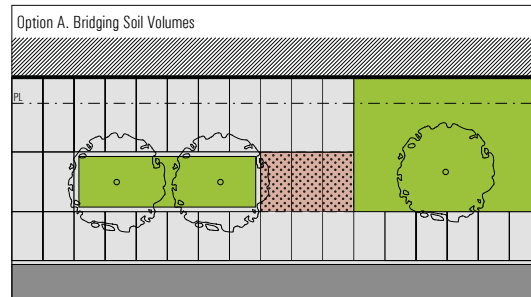

Legend

- building
- paved surface
- property line
- soft landscape
- soil cells



Example of soil cells being installed (Bloor St. W.)



References

Building Toronto Together: A Development Guide
toronto.ca/developing-toronto/darp_guide

City of Toronto Urban Forestry Website
toronto.ca/trees/

Development Infrastructure Policy and Standards (DIPS)
toronto.ca/wes/techservices/involved/transportation/future_streets/

Parks, Forestry & Recreation's Strategic Plan: Our Common Grounds
toronto.ca/parks/commongrounds

SPOA City Standard Construction Standards for Roads
toronto.ca/caldocuments/conspecs_roads

Toronto Green Standard
toronto.ca/planning/greendevlopment

Toronto Official Plan
toronto.ca/planning/official_plan

Toronto Public Utilities Coordinating Committee (TPUCC)
tpucc.com (password access only)

Toronto Urban Design Streetscape Manual
insideto.toronto.ca/streetscapemanual (internal City staff access only)

Transportation Services
Right of Way Mgmt, Permit Applications for work within the Public Right of Way



Toronto Street Trees



T-sL Planting Options: Soft Landscape | Spatial Requirements

Sidewalk conditions may vary. Required minimum widths subject to City approval. Refer to the Streetscape Manual for specification details.

General Notes:
¹ At least 15m³ of high quality soil should be provided per tree and each tree (through sharing or alone) should have direct access to at least 30m² of high-quality soil.
² High-quality soil shall consist of a minimum 0.9m and maximum 1.2m depth, over and above any required drainage system and/or granular material, be uncompacted, and be sandy loam with the following composition:
 Sand (50%-60%)
 Silt (20%-40%)
 Clay (0%-10%)
 Organic (2%-5%)
 pH = 7.5 or less
³ Especially within the first 2 years of establishment

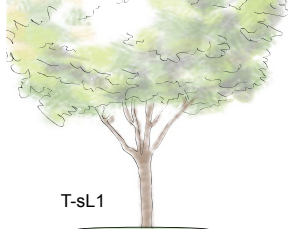

T-sL1

CURB	SOFT LANDSCAPE AREA	PEDESTRIAN CLEARWAY	MINIMUM TOTAL WIDTH REQUIRED
0.2m	5.5m	2.1m	7.80m
		1.7m	7.40m
		1.53m	7.23m
0.2m	3.2m	2.1m	5.50m
		1.7m	5.10m
		1.53m	4.93m
0.2m	2.0m*	2.1m	4.30m
		1.7m	3.90m
		1.53m	3.73m

T-sL1 Planting Between Curb and Sidewalk

- Refer to Streetscape Manual Standard Street Tree Design Details T-sL1 for complete specifications
- Trees planted 5.0m min. to 10.0m max. on centre (7.0m to 8.0m intervals recommended)
 - Where possible, use soil cells, structural soil or other approved technique to extend rooting zones below and beyond hard surfaces
 - Tree planting from curb: as far away from curb and as close to sidewalk as possible (do not centre in soft landscaped area unless 4.0m minimum offset from curb is achieved)
 - Tree planting from building face: 6.0m minimum recommended, 3.0m minimum¹

*A reduction from 3.2m to a minimum 2.0m wide soft landscaped area may be considered under the following conditions:
 a) Trees planted in a raised planting bed or protected by a fence/guard approved by the City of Toronto
 b) Additional growing environment exists below/beyond sidewalk (see notes above)

¹Planting less than 6.0m from a building face may limit tree size and compromise natural canopy shape resulting in more maintenance



T-sL2

CURB	PEDESTRIAN CLEARWAY	SOFT LANDSCAPE AREA	MINIMUM TOTAL WIDTH REQUIRED
0.2m	2.1m	3.2m	5.50m
			5.10m
			4.93m
0.2m	2.1m	2.0m*	4.30m
			3.90m
			3.73m
0.2m	2.1m	1.5m**	3.80m
			3.40m
			3.23m

T-sL2 Planting Between Sidewalk and Property Line

- Refer to Streetscape Manual Standard Street Tree Design Details T-sL2 for complete specifications
- Trees planted 5.0m min. to 10.0m max. on centre (7.0m to 8.0m intervals recommended)
 - Tree planting from edge of sidewalk: 1.5m min. recommended, 1.2m min. for balled and burlapped, 0.8m min. for bare root planting
 - Tree planting from building face: 6.0m minimum recommended, 3.0m minimum¹

*A reduction from 3.2m to a minimum 2.0m wide soft landscaped area may be considered under the following conditions:
 a) Trees planted in a raised planting bed or protected by a fence/guard approved by the City of Toronto
 b) Additional growing environment exists below/beyond sidewalk (see note below)

**1.5m minimum only if appropriate soil volume and planting conditions available beyond property line and/or within rest of boulevard. If area beyond property line is paved (e.g. parking lot, walkway, plaza, etc.) and/or does not support root growth, 3.2m required minimum

¹Planting less than 6.0m from a building face may limit tree size and compromise natural canopy shape resulting in more maintenance



T-sL3

CURB	SOFT LANDSCAPE AREA	PEDESTRIAN CLEARWAY	SOFT LANDSCAPE AREA	MINIMUM TOTAL WIDTH REQUIRED
0.2m	5.5m	2.1m	3.2m	11.00m
				10.60m
				10.43m
0.2m	3.2m	2.1m	3.2m	8.70m
				8.30m
				8.13m
0.2m	3.2m	2.1m	1.5m*	7.00m
				6.60m
				6.43m

T-sL3 Planting Double Row of Trees

- Refer to Streetscape Manual Standard Street Tree Design Details T-sL3 for complete specifications
- Trees planted 5.0m min. to 10.0m max. on centre (7.0m to 8.0m intervals recommended)
 - Offset/stagger each row for maximum canopy effect
 - Follow T-sL1 and T-sL2 for minimum widths, tree locations, planting and soil specifications
 - Tree planting areas should be equally high-quality for matched tree growth, otherwise apply single row only (T-sL1 or T-sL2)
 - Tree planting from building face: 6.0m minimum recommended, 3.0m minimum¹

*1.5m minimum only if appropriate soil volume and planting conditions available beyond property line and/or within rest of boulevard. If area beyond property line is paved (e.g. parking lot, walkway, plaza, etc.) and/or does not support root growth, 3.2m required min.

¹Planting less than 6.0m from a building face may limit tree size and compromise natural canopy shape resulting in more maintenance

T- Planting Options: Hard Landscape | Spatial Requirements

Sidewalk conditions may vary. Required minimum widths subject to City approval. Refer to the Streetscape Manual for specification details.

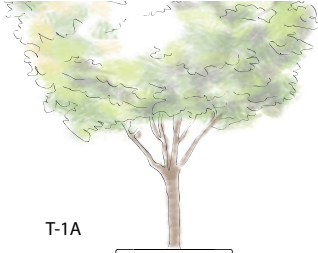

T-1A

CURB/ EDGE ZONE	CONTINUOUS TREE TRENCH	PEDESTRIAN CLEARWAY	MINIMUM TOTAL WIDTH REQUIRED
0.815m	1.83m	2.1m	4.75m
0.4m			4.33m

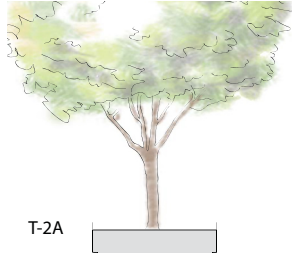

T-2A

CURB/ EDGE ZONE	CONTINUOUS TREE TRENCH + raised planter overhang	PEDESTRIAN CLEARWAY	MINIMUM TOTAL WIDTH REQUIRED
0.765m*	1.83m	2.1m	4.80m
0.46m**	+ 0.1m (50mm each side)**		4.49m



CURB/ EDGE ZONE	CONTINUOUS TREE TRENCH	PEDESTRIAN CLEARWAY	MINIMUM TOTAL WIDTH REQUIRED
0.815m	1.83m	2.1m*	4.75m
0.4m			4.33m
0.815m	1.83m	1.7m	4.35m
0.4m			3.93m
0.815m	1.83m	1.53m	4.18m
0.4m			3.76m

T-1 Open Planting Bed

T-1A Concrete Sidewalk / T-1B Unit Paved Sidewalk

Refer to Streetscape Manual Standard Street Tree Design Details T-1 for complete specifications

- Trees planted 5.0m min. to 10.0m max. on centre (7.0m to 8.0m intervals recommended)
- Length of open planting bed varies depending on space available. Minimum curb length is 1800mm. Length typically increased in 1800mm increments
- Extend continuous soil trench or planting bed a minimum of 2700mm (4500mm recommended) beyond the last tree planted at each end of the trench
- Open planting bed must have 7.2m min. curb length to plant more than 1 tree

T-2 Raised Planter

T-2A Concrete Sidewalk / T-2B Unit Paved Sidewalk

Refer to Streetscape Manual Standard Street Tree Design Details T-2 for complete specifications

- Trees planted 5.0m min. to 10.0m max. on centre (7.0m to 8.0m intervals recommended)
- Extend continuous soil trench or planting bed a minimum of 2700mm (4500mm recommended) beyond the last tree planted at each end of the trench

*Minimum dimension for two-rows of pavers (815mm) minus raised planter curb-side overhang (± 50mm)

**Minimum required setback from curb face to vertical obstruction

***Typical raised planter overhang, but varies depending on design and decorative treatments applied (total minimum required width must be adjusted to reflect raised planter design and dimensions)

T-3 Planter Cover

T-3A Concrete Sidewalk / T-3B Unit Paved Sidewalk

Refer to Streetscape Manual Standard Street Tree Design Details T-3 for complete specifications

- Trees planted 5.0m min. to 10.0m max. on centre (7.0m to 8.0m intervals recommended)
- Extend continuous soil trench or planting bed a minimum of 2700mm (4500mm recommended) beyond the last tree planted at each end of the trench

*Option T-3 is for narrow/crowded conditions only. Where 2.1m or greater pedestrian clearance is available in the public ROW or secured with an easement on private property, consider planting option T-1

